

WOODWORKS: INTERMEDIATE PROJECT 2008-2009
OCCASIONAL TABLE

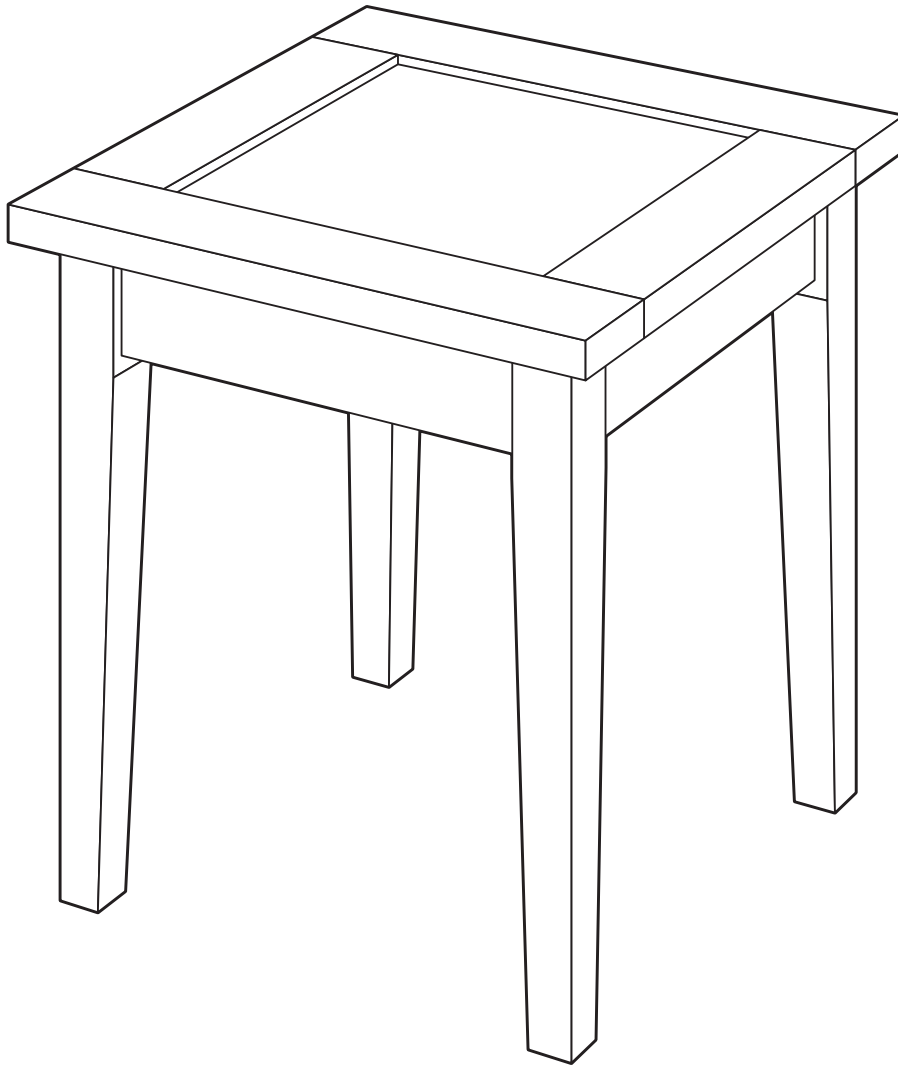

Here's a nice, small-sized table that can be put to good use in many rooms, from bedrooms to living and family rooms. And its traditional yet clean-lined design will help it to go well with any decorating style.

Making one of these tables will be an excellent exercise for intermediate woodworkers because it entails several techniques that will increase your skills: tapering the table legs, making single- and double-biscuit joints, making a solid wood panel, plus making grooves and rabbets. And when it's all assembled, you'll learn more about applying and using stains and finishes to protect the wood and keep it looking beautiful.

TOOLS REQUIRED**Hand Tools**

Bar and C-clamps
Wood or rubber mallet

Power Tools

Table saw
Band saw
Jointer
Biscuit joiner
Random-orbit sander

Miscellaneous

- Pencil
- Tape measure
- Safety glasses
- Carpenter's glue
- 120-, 150- and 220-grit sandpaper
- Clean, lint-free cloths
- Respirator
- Gloves for finishing
- Mineral spirits (for oil-based stains and finishes)
- Water-filled metal container with tight-fitting lid (for oil-based stains and finishes)
- Minwax® Wood Finish™ Stain Brush or other good quality, natural-bristle brush (for oil-based stains and finishes)

SHOPPING LIST

Wood Recommendation: Maple and walnut (panel)

Alternate Wood: Oak and mahogany (panel)

4 lin. ft. 8/4x4

10 lin. ft. 5/4x4

3 lin. ft. 1x4

4 lin. ft. 1x4 walnut or mahogany

#20 biscuits, 30 pcs.

CUTTING LIST

Overall dimensions: 18" x 18" x 19"

Item	Description	Size & Quantity
A	Leg	1-3/4" x 1-3/4" x 19", 4 pcs.
B	Apron	1" x 3" x 12-3/4", 4 pcs.
C	Long frame	1" x 3" x 18", 2 pcs.
D	Short frame	1" x 3" x 12", 2 pcs.
E	Panel	5/8" x 12-1/2" x 12-1/2", 1 pc.
F	Gluing blocks	3/4" x 3/4" x 3", 8 pcs.

WOOD FINISHING PRODUCTS**Recommended Finish**

Prep: Minwax® Pre-Stain Wood Conditioner
Stain: Minwax® Gel Stain Cherrywood
Minwax® Gel Stain Brazilian Rosewood (center tile)
Finish: Minwax® Fast-Drying Polyurethane

Alternate Finish

Prep: Minwax® Pre-Stain Wood Conditioner
Stain: Minwax® Polyshades® Mission Oak
Minwax® Polyshades® Pecan (center tile)

BEFORE YOU BEGIN

Good craftsmanship begins and ends with good work habits, so make the following steps part of your routine workshop practice. If you have any doubts or questions about how to proceed with a project, always discuss them with your shop instructor.

- Carefully and fully review plans and instructions before putting a tool to the project lumber.
- Work sensibly and safely. Wear safety goggles when doing work that creates flying chips and sawdust; wear the appropriate respirator whenever making sawdust or working with thinners or other solvents.
- At the end of every work session, clean up your shop area and put away all portable tools.

CUTTING AND ASSEMBLY PROCEDURE

1. Saw the 8/4 material for the legs (A) 1/8" oversize. Then joint, plane and cut them to the final size.

2. Mark an X at the top of two adjacent sides on each leg. The tapers are subtle and it's possible to confuse them with the untapered outer sides. Also, where the tapered sides join the aprons, they must be untapered (see Fig. 1), so the taper cuts must stop 3-1/2" from the top of each leg.

3. Mark lines for the tapers on each leg and saw the taper on the band saw. Stay about 1/16" away from your pencil line (see Fig. 2). Always use a pushstick when cutting narrow boards. After the first taper is cut, reattach the resulting scrap with masking tape and cut the second taper. Remove band saw marks with a pass or two over the jointer.

4. To cut the double biscuit slots in the legs, use spacers as shown in Figure 3. This setup works with any biscuit joiner and the only measuring you need to do is to locate the centerline of the slots, measuring down 1-1/2" from the top of the legs. Cut the first slot using the 1/4" spacer. Then put the 3/8" spacer on top of it and cut the second slot. Each leg will thus have two pairs of slots. Make sure to cut the slots with the adjacent tapered side of the leg side down on the worktable. Use a clamp to hold the leg while you work.

5. Cut the aprons (B) to length from the 5/4 stock. To cut the double biscuit slots in the ends of the aprons, clamp the apron face-side down. Cut the first slot without the 1/4" spacer; then put the 3/8" spacer in place to cut the second slot (Fig. 4). This is a foolproof system for making the slots in the legs and aprons exactly the same distance apart.

6. Glue the legs and aprons together one side at a time. Wipe away excess glue before it dries. After the glue has dried, complete the table base by gluing and clamping the remaining two apron pieces (Fig. 5).

7. Cut the long (C) and short (D) frame pieces to the required length and width. Cut double biscuit slots into the ends of the short frame pieces and into the edges of the long frame pieces. Use the same technique described in step 5.

8. Cut 1/4"-wide x 3/8"-deep grooves into the inside edges of all the frame pieces, 1/4" down from the top face of the frame to create the

recess for the panel (see Fig. 1). The groove in the long frame pieces must be stopped so it doesn't show through the end grain.

9. Cut the panel material to the required lengths (E). Joint the edges to make them perfectly straight and square. Cut two biscuit slots into each edge (except the outside edges of the pieces that will be used for the outside edges of the panel). Glue and insert the biscuits, glue the edges and clamp all the pieces together. Wipe away excess glue before it dries.

10. When the panel glue has dried, cut the panel to the final dimensions on the table saw. Then equip the saw with a dado blade and set it to cut a 1/2" -deep x 1/2" -wide rabbet along the edges of the panel (see Fig. 1). Test the fit of the resulting lip in the grooves of the frame pieces. It should be snug but not too tight.

11. Before assembling the frame and panel pieces, finish-sand the exposed inside edges of the frame and the top face of the panel. It's easier to do this now than after the tabletop is assembled. You must also stain and finish the center panel before it is enclosed by the frame pieces.

12. Glue and insert the biscuits and the ends of the frame pieces. Assemble the frame pieces around the panel and clamp the corners tightly together. Wipe away excess glue before it dries. After the glue is dry, finish-sand the frame so that all the joints are perfectly smooth.

13. Cut the gluing blocks (F) to size and glue them to the inside faces of the apron, two per side (see Fig. 1).

14. When the glue has dried, apply glue to the top edge of the apron, and the tops of the gluing blocks and legs. Position the tabletop so that it overhangs the table base equally on all sides, and use deep C-clamps to secure the assembly. Wipe away excess glue before it dries.

STAINING AND FINISHING

Woodworker's Tip: *Though you may be tempted to cut short your sanding, preparation and application time, don't do it. These tasks are very important steps in obtaining a high-quality finish. Remember, it is the finish, just as much as the fit and smoothness of the parts that will have great bearing on how people judge your craftsmanship. To ensure an excellent result, follow the steps listed in this section and also the instructions the finish manufacturer puts on its products.*

FINISHING TIPS

- Test the stains and finishes you are planning to use on scraps of wood. On the back of the scrap, mark the stain/finish combination and the type of wood. Allow all samples to dry thoroughly before making your final finish selection. Save your samples for quick reference on future projects.
- All stains and finishes must be allowed to dry thoroughly between coats. Remember that drying times can vary due to humidity and other climatic conditions.
- If you have some leftover stain or finish, wipe the can rim so that stain or finish in the rim won't dry out and prevent the lid from forming a tight seal.
- Brushes used for oil-based finishes must be cleaned with mineral spirits.

15. Finish-sand any remaining rough spots with 220-grit paper. Dust off the piece and wipe it carefully with a clean, lint-free cloth lightly dampened with mineral spirits.

Recommended Finish

16. Apply Minwax® Gel Stain Cherrywood to the table frame and Minwax® Gel Stain Brazilian Rosewood to the center panel using a clean, lint-free cloth or natural-bristle brush. Follow the directions on the can. Allow the Gel Stain to set for about 3 minutes, then wipe off any excess with a clean, lint-free cloth. To achieve a deeper color, you may apply a second coat after 8 to 10 hours, repeating the application directions for the first coat. Allow the stain to dry for 24 hours before applying the finish.

Woodworker's Tip: *When wiping off stain, make certain that your last wipe with the cloth goes with the grain of the wood. This way, any stain you might miss during wipe-off will be visually minimized by the wood grain.*

17. Apply Minwax® Fast-Drying Polyurethane following the directions on the can. Use a good quality, natural-bristle brush. Allow the first coat to dry overnight.

18. The next day, sand all surfaces lightly with 220-grit or finer sandpaper using with-the-grain strokes. Dust off and wipe all surfaces with a cloth lightly dampened with mineral spirits. Apply a second coat of polyurethane and set the piece aside to cure overnight.

19. The following day, sand all surfaces lightly with 220-grit paper. Dust off and wipe the piece with a cloth lightly dampened with mineral spirits and apply the third and final coat of polyurethane.

Alternate Finish

20. Apply Minwax® Polyshades® Mission Oak to the table frame and Minwax® Polyshades® Pecan to the center panel following the directions on the can. Use a good quality, natural-bristle brush suitable for use with polyurethane. Stir the can contents thoroughly before starting and periodically repeat stirring during your work session. Allow the first coat to dry overnight.

21. The next day, sand all surfaces lightly with 220-grit sandpaper or very fine (000) steel wool using with-the-grain strokes. Dust off and wipe all surfaces with a cloth dampened with mineral spirits. Apply a second coat of Polyshades® and set the rack aside to cure overnight. To achieve a deeper color, you may apply a third coat after 4 to 6 hours, repeating the application directions. Allow the table to cure for several days before using it.

Woodworker's Tip: *If you achieve the desired color on the first or second coats of Polyshades®, apply a clear coat of Minwax® Fast-Drying Polyurethane or Minwax® Wipe-On Poly for added protection.*

PRODUCT SAFETY

For your safety and the safety of those you work with, always read the safety warnings, which manufacturers print on their labels, and follow them to the letter.

WARNING! Removal of old paint by sanding, scraping or other means may generate dust or fumes that contain lead. Exposure to lead dust or fumes may cause brain damage or other adverse health effects, especially in children or pregnant women. Controlling exposure to lead or other hazardous substances requires the use of proper protective equipment, such as properly fitted respirator (NIOSH approved) and proper containment and cleanup. For more information, call the National Lead Information Center at 1-800-424-LEAD (in U.S.) or contact your local health authority.

DANGER: Rags, steel wool, other waste soaked with oil-based stains and clear finishes, and sanding residue may spontaneously catch fire if improperly discarded. Immediately place rags, steel wool, other waste soaked with this product, and sanding residue in a sealed, water-filled metal container. Dispose of in accordance with local fire regulations.

When using oil-based wood finishing products:

CAUTIONS: CONTAINS ALIPHATIC HYDROCARBONS.

Contents are **COMBUSTIBLE**. Keep away from heat and open flame. **VAPOR HARMFUL**. Use only with adequate ventilation. To avoid over-exposure, open windows and doors or use other means to ensure fresh air entry during application and drying. If you experience eye watering, headaches, or dizziness, increase fresh air, or wear respiratory protection (NIOSH approved), or leave the area. Avoid contact with eyes and skin. Wash hands after using. Keep container closed when not in use. Do not transfer contents to other containers for storage.

FIRST AID: In case of eye contact, flush thoroughly with large amounts of water for 15 minutes and get medical attention. For skin contact, wash thoroughly with soap and water. In case of respiratory difficulty, provide fresh air and call physician. If swallowed, call Poison Control Center, hospital emergency room, or physician immediately.

DELAYED EFFECTS FROM LONG-TERM OVEREXPOSURE.

Contains solvents which can cause permanent brain and nervous system damage. Intentional misuse by deliberately concentrating and inhaling contents may be harmful or fatal.

WARNING: This product contains a chemical known to the State of California to cause cancer and birth defects or other reproductive harm. **DO NOT TAKE INTERNALLY. KEEP OUT OF REACH OF CHILDREN.**

CONFORMS TO ASTM D-4326. Contact a physician for more health information.

When using water-based wood finishing products:

CAUTIONS: Use Only With Adequate Ventilation. To avoid overexposure, open windows and doors or use other means to ensure fresh air entry during application and drying. If you experience eye watering, headaches, or dizziness, increase fresh air, or wear respiratory protection (NIOSH approved), or leave the area. Avoid contact with eyes and skin. Wash hands after using. Keep container closed when not in use. Do not transfer contents to other containers for storage.

FIRST AID: In case of eye contact, flush thoroughly with large amounts of water. Get medical attention if irritation persists. If swallowed, get medical attention immediately.

WARNING: This product contains a chemical known to the State of California to cause cancer and birth defects or other reproductive harm.
DO NOT TAKE INTERNALLY. KEEP OUT OF REACH OF CHILDREN.
CONFORMS TO ASTM D-4326. Contact a physician for more health information.

FIG 1.

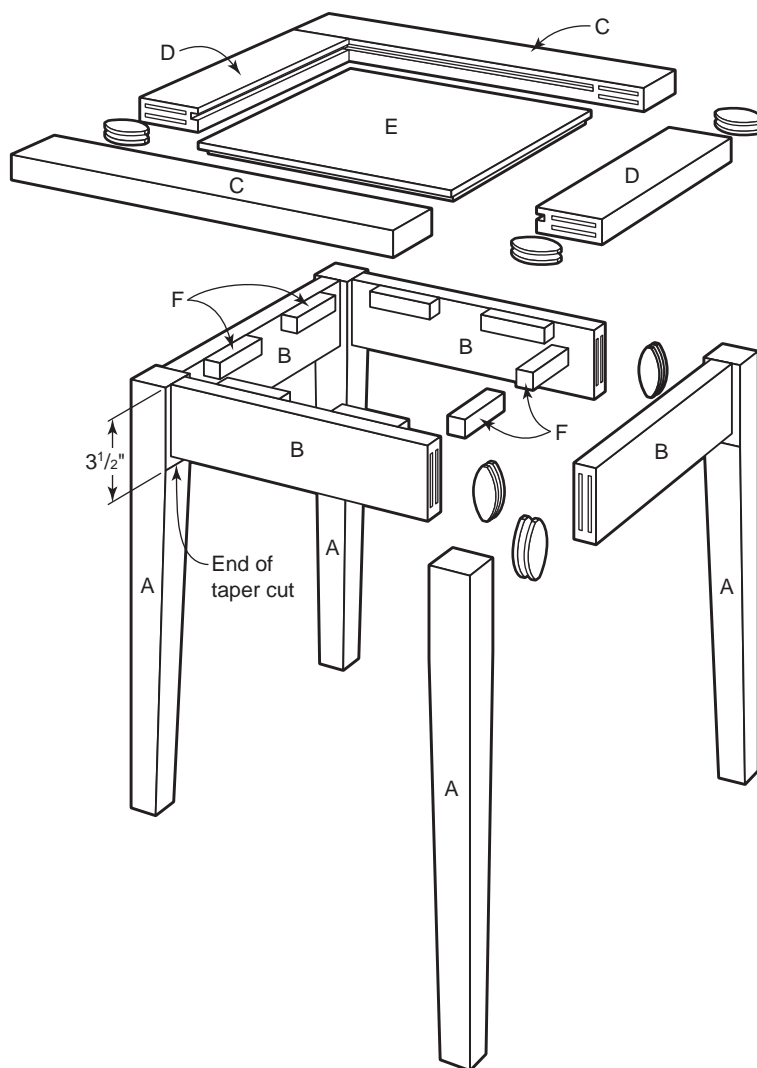

FIG 2.

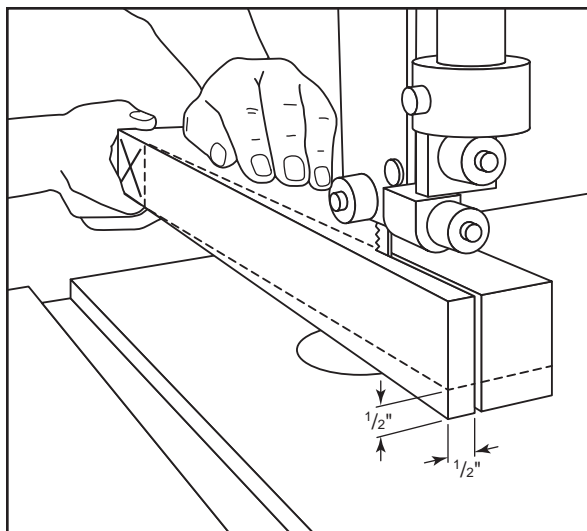

FIG 3.

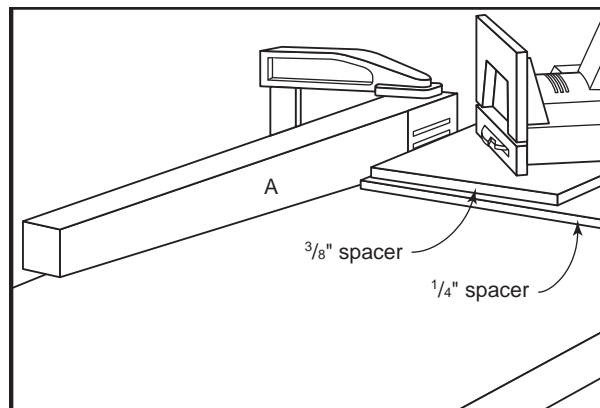

FIG 4.

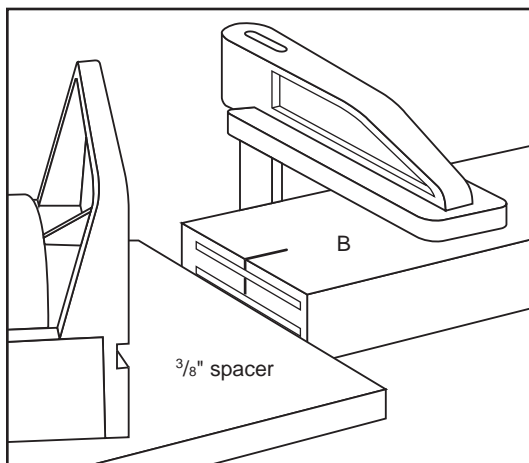

FIG 5.

