

WOODWORKS: BEGINNER PROJECT 2010-2011
SKATEBOARD RACK

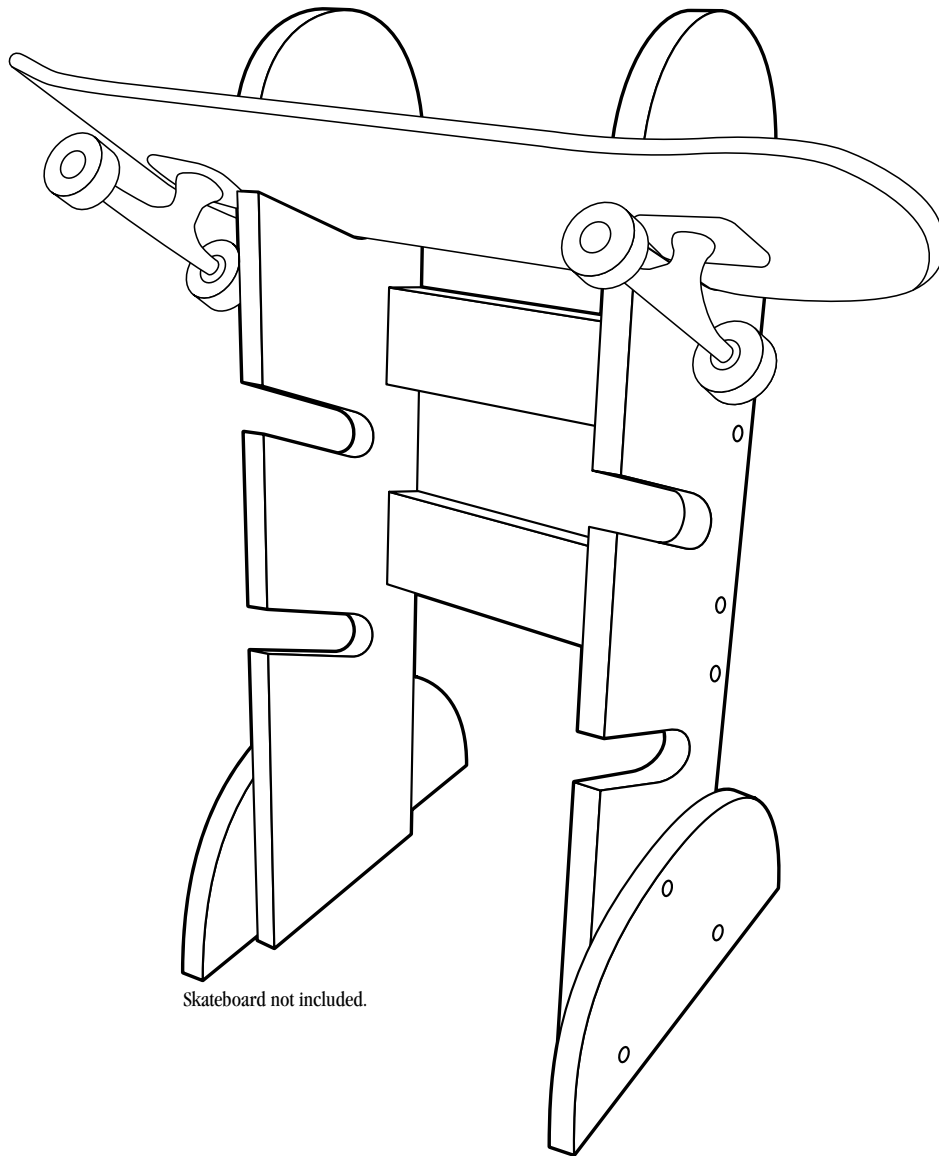

Skateboard not included.

If you're a skateboarder, or there's one in your family, you know the boards are hard to store, if they get put away at all! Here's a quick and easy way to corral loose skateboards with a sturdy, stable rack that holds three of them. You can also enlarge this design to handle a trio of snowboards. Either way, it's an inexpensive project, and for beginner-level woodworkers it's a great way to sharpen layout skills and do some precision drilling and band saw work. And after you build it, you will learn more about applying and using finishes to protect the wood and keep it looking beautiful.

TOOLS REQUIRED

Hand Tools

- Wood file
- Sanding block
- Pipe or bar clamps
- Adjustable square
- Bevel gauge
- Compass
- Protractor

Power Tools

- Table saw
- Miter saw
- Drill press with 1-1/4" and 3/8" Forstner bits, standard drill bits and 3/8" plug cutter
- Router with 1/8" roundover bit
- Power drill with drill bits, Phillips-head screwdriver bit
- Orbital or finish sander

Miscellaneous

- Tape measure
- Pencil
- Safety glasses
- Carpenter's glue
- 120-grit sanding belt
- 120-, 150- and 220-grit sandpaper
- Clean, lint-free cloths
- Respirator
- Gloves for finishing
- Mineral spirits, for cleanup of oil based finishes
- Good quality, natural-bristle brush for oil based finishes or synthetic-bristle brush for water-based finishes

SHOPPING LIST

Wood Recommendation: Pine

Alternate Wood: Red or White Oak

Part	Qty.	Th. x W x L
A, B, C	1	1" x 8" x 8' pine
Woodscrews	14	#8 x 3" flathead, Phillips-head

CUTTING LIST

Overall Dimensions: 13" W x 28" H x 14" D			
Part	Name	Qty.	Th. x W x L
A	Uprights	2	3/4" x 7" x 28-1/8"
B	Stretchers	2	3/4" x 3" x 10"
C	Feet	2	3/4" x 7" x 14"

Snowboard Option

To modify this design for snowboards, substitute 1x10s for the 1x8s, and make the slots about 6" deep. The stretchers should be about 31" long. The following shopping and cutting lists have been altered accordingly; the assembly directions are the same.

SHOPPING LIST

Wood Recommendation: Pine

Alternate Wood: Red or White Oak

Part	Qty.	Th. x W x L
A, B, C	1	1" x 10" x 10' pine
Woodscrews	14	#8 x 3" flathead, Phillips-head

CUTTING LIST

Overall Dimensions: 13" W x 28" H x 14" D			
Part	Name	Qty.	Th. x W x L
A	Uprights	2	3/4" x 9" x 28-1/8"
B	Stretchers	2	3/4" x 4" x 31"
C	Feet	2	3/4" x 9" x 16"

Radius of curve on top of A = 4"

Radius of curve on top of C = 8"

WOOD FINISHING PRODUCTS

Recommended Finish

- Prep: Minwax® Water-Based Pre-Stain Wood Conditioner
 Stain: Minwax® Water-Based Wood Stain Mustard (legs and back) and Classic Black (stand)
 Finish: Minwax® Polycrylic® Protective Finish Semi-Gloss

Alternate Finish

- Prep: Minwax® oil based Pre-Stain Wood Conditioner
 Stain/Finish: Minwax® PolyShades® American Chestnut Gloss

BEFORE YOU BEGIN

Good craftsmanship begins and ends with good work habits, so make the following steps part of your routine workshop practice. If you have any doubts or questions about how to proceed with a project, always discuss them with your shop instructor.

- Carefully and fully review plans and instructions before putting a tool to the project lumber.
- Work sensibly and safely. Wear safety goggles when doing work that creates flying chips and sawdust; wear the appropriate respirator whenever making sawdust or working with thinners or other solvents.
- At the end of every work session, clean up your shop area and put away all portable tools.

CUTTING AND ASSEMBLY PROCEDURE

1. Rip the 1x8 down to 7" wide. Cut part A, two pieces, 1/4" longer than the finished length. Cut part B to its finished length and rip the board into two 3" wide pieces. Cut part C, two pieces, 1/4" longer than the finished length.
2. On one of the pieces for the feet (C), lay out a semicircle with a 7" radius, as shown in Fig. 2, using a standard compass or a beam compass.
3. Using double-faced tape to join them, place the layout piece over the other piece, aligning both sides and ends.
4. Cut the curve of the feet with a band saw or jigsaw (see Fig. 3).
5. Use double-faced tape to join the two uprights, again aligning the sides and the ends.
6. Set up a miter saw for a 6° angle cut. Cut the angle into one end of the two pieces.
7. Keeping the pieces together, lay out the hole and slot locations as shown in Fig. 2. Be careful to measure from the front, the long point, of the 6° angle.
8. Drill the 1-1/4" holes with a drill press fitted with a Forstner or spade bit. To ensure consistency, set up a fence so the holes are all the same distance from the edge.
9. Set a bevel gauge to 20°. Mark out the lines for the slots by making the edge of the square tangent to the edge of the 1-1/4" hole. Make sure you're marking from the front edge.
10. Lay out the curve at the top of the uprights. It's a semicircle with a 3-1/2" radius.
11. Cut the curve and the slots with a band saw or jigsaw (see Fig. 4).
12. Use a file to clean up the saw marks on the slots and make them straight.
13. Ease all the edges of all the pieces (except the ends of the stretchers, B) with a router fitted with a 1/8" roundover bit that has a guide bearing.

14. Lay out the screw hole locations on the feet and the uprights as shown in Fig. 2. Make sure to do layouts for a left and a right upright.

15. Start the drilling for the holes by using a 3/8" Forstner bit and drilling down 1/4" to allow for wood plugs after the rack is assembled.

16. Glue and screw the feet to the uprights.

17. Use a toothpick to apply glue inside the holes. Tap the plug in, and trim it flush with a sharp chisel. Sand to finish.

18. Screw and glue the uprights to the stretchers. Use 3/4" thick spacer blocks at the back to properly position the stretchers. Use a 10" long piece of scrap as a spacer at the front so the uprights, stretchers and spacer blocks can be temporarily clamped, as shown in Fig. 5. When the screws are in, plug the holes and sand them smooth.

STAINING AND FINISHING

Woodworker's Tip: Though you may be tempted to cut short your sanding, preparation and application time, don't do it. These tasks are very important steps in obtaining a high-quality finish. Remember, it is the finish, just as much as the fit and smoothness of the parts that will have great bearing on how people judge your craftsmanship. To ensure an excellent result, follow the steps listed in this section and also the instructions the finish manufacturer puts on its products.

FINISHING TIPS

- Test the stains and finishes you are planning to use on scraps of wood. On the back of the scrap, mark the stain/finish combination and the type of wood. Allow all samples to dry thoroughly before making your final finish selection. Save your samples for quick reference on future projects.
- All stains and finishes must be allowed to dry thoroughly between coats. Remember that drying times can vary due to humidity and other climatic conditions.
- If you have some leftover stain or finish, wipe the can rim so that stain or finish in the rim won't dry out and prevent the lid from forming a tight seal.
- Brushes used for oil based finishes must be cleaned with mineral spirits.

19. Finish-sand all surfaces, starting with 120-grit sandpaper and finishing with 220-grit sandpaper. Dust off the piece and wipe it carefully with a clean, lint-free cloth lightly dampened with mineral spirits.

Recommended Finish

20. Before applying Minwax® Water-Based Wood Stain, apply Minwax® Water-Based Pre-Stain Wood Conditioner, following the directions on the can. Applying it will help to ensure even absorption of stain, prevent blotchiness that can occur and minimize grain raise. After 1 to 5 minutes, wipe off all excess conditioner using a clean, soft cloth. Wait 15 to 30 minutes, then use 220-grit or finer sandpaper to sand off any "whiskers" raised by the conditioner. Proceed to the staining within 2 hours.

21. Apply the Minwax® Water-Based Wood Stain you've chosen to the wood using either a nylon/polyester brush or a clean cloth. Allow stain to penetrate no longer than 3 minutes. While stain is still wet, wipe off all excess with a clean cloth that's been lightly dampened with stain. Allow the piece to dry for 2 hours before applying a second coat, if desired.

22. After allowing the piece to dry for at least 3 hours, apply Minwax® Polycrylic® Protective Finish, following the directions on the can. Stir the can contents thoroughly before starting and periodically repeat the stirring during your work session.

23. Working a small area at a time to maintain a wet edge, apply the first coat. Work quickly and make the final strokes in each newly finished section using with-the-grain brushstrokes.

24. Allow the finish to dry a minimum of 2 hours. Then sand lightly with 220-grit or finer sandpaper wrapped around a soft backup block. Thoroughly dust off and wipe all surfaces with a cloth lightly dampened with water.

25. Repeat steps 23 and 24 to apply the second and final coat. Do not sand after the final coat. Allow the finish to cure for several days before using the rack.

Alternate Finish

26. Before applying Minwax® Polyshades® to softwood such as pine, apply Minwax® oil based Pre-Stain Wood Conditioner, following the directions on the can. Applying the pre-stain conditioner will help to ensure even absorption of stain and prevent blotchiness.

27. Apply Minwax® Polyshades®, following the directions on the can. Use a good quality, natural-bristle brush suitable for use with polyurethane. Stir the can contents thoroughly before starting and periodically repeat stirring during your work session. Allow the first coat to dry for at least 6 hours.

28. For a second coat, sand all surfaces lightly with 220-grit sandpaper or very fine (000) steel wool using with-the-grain strokes. Dust off and wipe all surfaces with a cloth dampened with mineral spirits. Apply a second coat of Polyshades® and set the rack aside to cure overnight. To achieve a deeper color, you may apply a third coat after 4 to 6 hours, repeating the application directions. Allow the finish to cure for several days before using the rack.

Woodworker's Tip: *If you achieve the desired color on the first or second coats of Polyshades®, apply a clear coat of Minwax® Fast-Drying Polyurethane or Minwax® Wipe-On Poly for added protection.*

PRODUCT SAFETY

For your safety and the safety of those you work with, always read the safety warnings, which manufacturers print on their labels, and follow them to the letter.

WARNING! Removal of old paint by sanding, scraping or other means may generate dust or fumes that contain lead. Exposure to lead dust or fumes may cause brain damage or other adverse health effects, especially in children or pregnant women. Controlling exposure to

lead or other hazardous substances requires the use of proper protective equipment, such as a properly-fitted respirator (NIOSH approved) and proper containment and cleanup. For more information, call the National Lead Information Center at 1-800-424-LEAD (in U.S.) or contact your local health authority.

DANGER: Rags, steel wool, other waste soaked with oil based stains or clear finishes, and sanding residue may spontaneously catch fire if improperly discarded. Immediately place rags, steel wool, other waste soaked with this product, and sanding residue in a sealed, water-filled metal container. Dispose of in accordance with local fire regulations.

When using oil based wood finishing products:

CAUTIONS: CONTAINS ALIPHATIC HYDROCARBONS.

Contents are **COMBUSTIBLE**. Keep away from heat and open flame. **VAPOR HARMFUL**. Use only with adequate ventilation. To avoid overexposure, open windows and doors or use other means to ensure fresh air entry during application and drying. If you experience eye watering, headaches, or dizziness, increase fresh air, or wear respiratory protection (NIOSH approved), or leave the area. Avoid contact with eyes and skin. Wash hands after using. Keep container closed when not in use. Do not transfer contents to other containers for storage.

FIRST AID: In case of eye contact, flush thoroughly with large amounts of water for 15 minutes and get medical attention. For skin contact, wash thoroughly with soap and water. In case of respiratory difficulty, provide fresh air and call physician. If swallowed, call Poison Control Center, hospital emergency room, or physician immediately.

DELAYED EFFECTS FROM LONG-TERM OVEREXPOSURE.

Contains solvents which can cause permanent brain and nervous system damage. Intentional misuse by deliberately concentrating and inhaling contents may be harmful or fatal.

WARNING: This product contains a chemical known to the State of California to cause cancer and birth defects or other reproductive harm.

DO NOT TAKE INTERNALLY. KEEP OUT OF REACH OF CHILDREN. CONFORMS TO ASTM D-4326. Contact a physician for more health information.

When using water-based wood finishing products:

CAUTIONS: Use Only With Adequate Ventilation. To avoid overexposure, open windows and doors or use other means to ensure fresh air entry during application and drying. If you experience eye watering, headaches, or dizziness, increase fresh air, or wear respiratory protection (NIOSH approved), or leave the area. Avoid contact with eyes and skin. Wash hands after using. Keep container closed when not in use. Do not transfer contents to other containers for storage.

FIRST AID: In case of eye contact, flush thoroughly with large amounts of water. Get medical attention if irritation persists. If swallowed, get medical attention immediately.

WARNING: This product contains a chemical known to the State of California to cause cancer and birth defects or other reproductive harm.

DO NOT TAKE INTERNALLY. KEEP OUT OF REACH OF CHILDREN. CONFORMS TO ASTM D-4326. Contact a physician for more health information.

FIG 1.

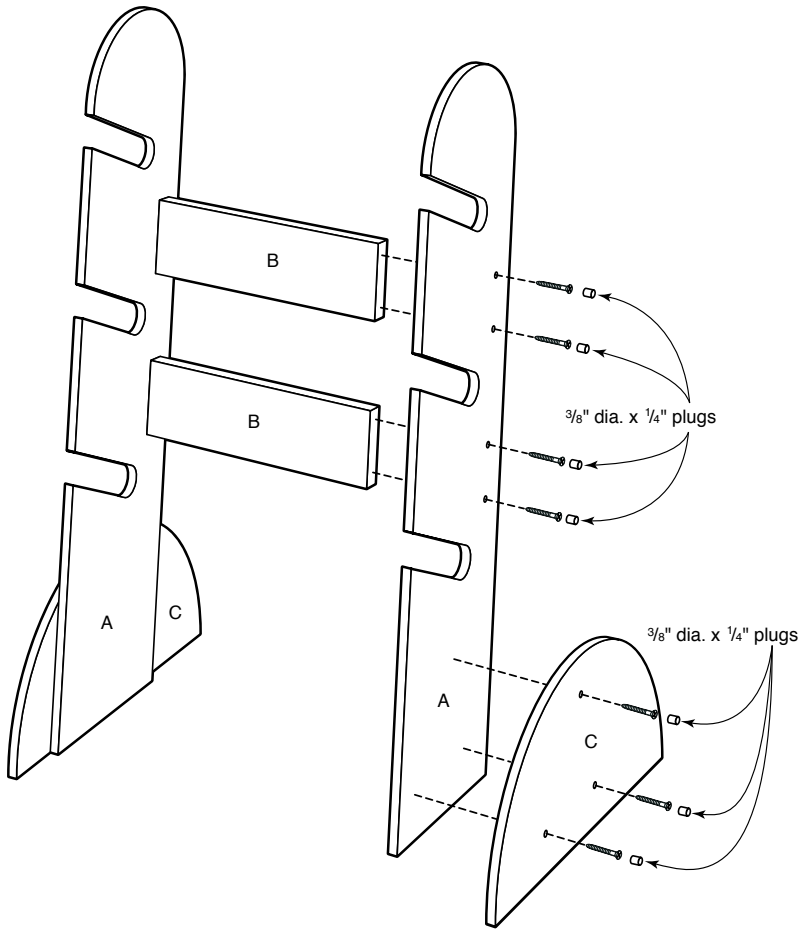

FIG 2.

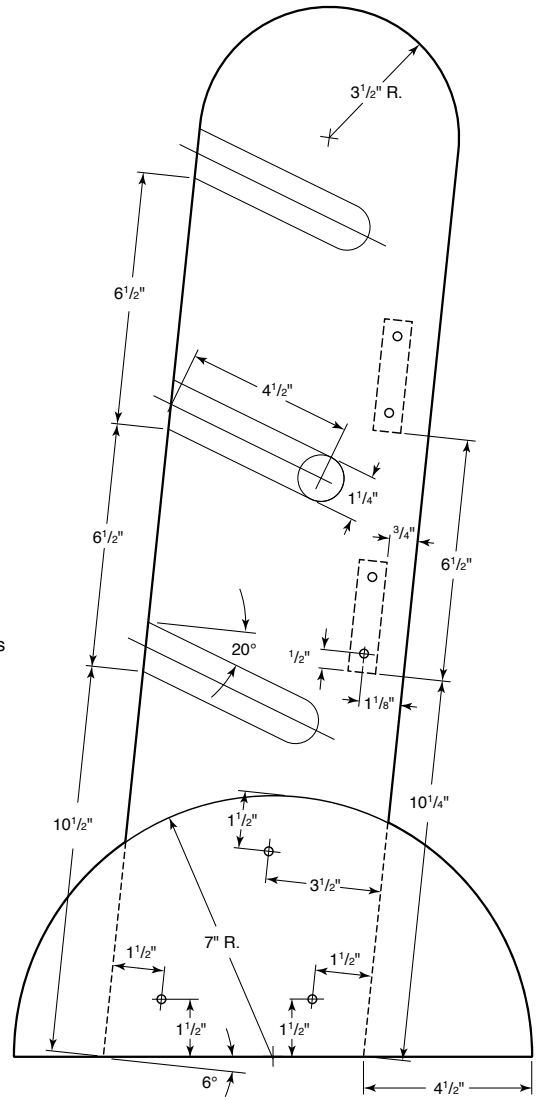

FIG 3.

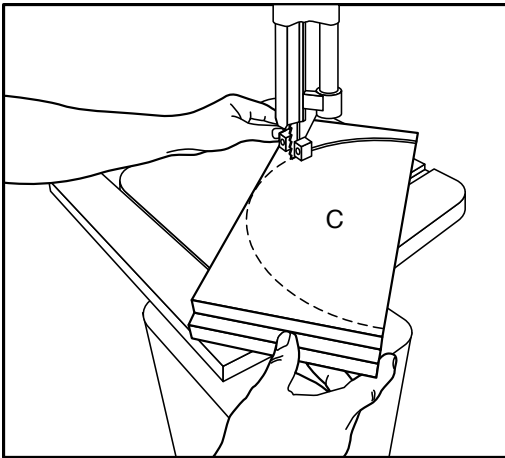

FIG 4.

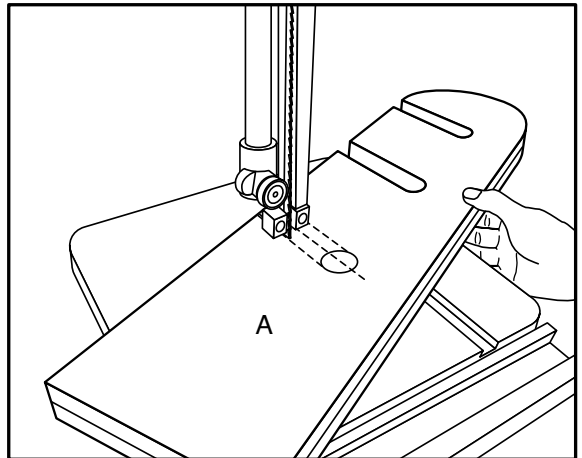

FIG 5.

