

WOODWORKS: ADVANCED PROJECT 2013-2014
SWIVELING STORAGE

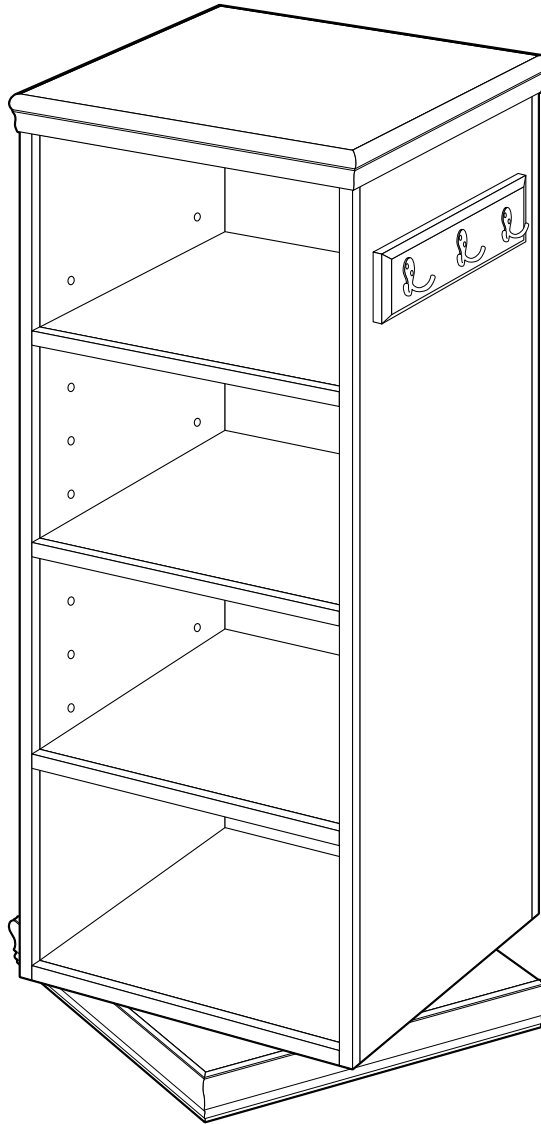

Room full of clutter? Bookshelves overflowing? Maybe it's time for more storage space. If you need some help managing the mess in your bedroom while helping you stay organized, consider this unique idea: A bank of large shelves that can swivel 360° with bonus coat hooks for hanging anything and a cork board for pinning everything.

It's a challenging project for advanced woodworkers, requiring lots of precision cutting, fitting and assembling. You'll add to your experience with plywood edge-banding, biscuit joinery, and mitered trimwork. And after you build it, you will learn more about applying and using finishes to protect the wood and keep it looking beautiful.

TOOLS REQUIRED

Hand Tools

- Sharp putty knife
- Adjustable square

Power Tools

- Table saw
- Router table
- Router
- Miter saw
- Planer or surface sander
- Orbital or finish sander

Miscellaneous

- Tape measure
- Pencil
- Wood glue
- Safety glasses
- 120- and 220-grit sandpaper
- Sanding block
- Clean, lint-free cloths
- Respirator
- Gloves for finishing
- Mineral spirits, for cleanup of oil-based finishes
- Good quality, natural-bristle brush (for oil-based finishes)
- Good quality synthetic-bristle brush (for water-based finishes)

SHOPPING LIST

Recommended Wood: Solid Oak and Oak Plywood

Parts	Material	Quantity
A, C, G, I, N	3/4" oak veneer plywood	2 sheets
B, D, J, K, M, O	3/4" × 3-1/2" solid oak	12'
H	1-1/2" wide oak chair rail	8'
L	2-1/2" wide oak chair rail	8'
P	Lazy Susan, item #22773	1 (www.rockler.com)
Other:	Shelf Supports, item #22773	12 (www.rockler.com)
	Robe Hooks, item #173116	6 (www.homedepot.com)
	#20 biscuits	40

CUTTING AND PARTS LIST

Swiveling Storage			
Part	Name	Qty	Dimension
A	Case Part	2 (plywood)	3/4" × 19" × 46"
B	Case Banding	4	3/4" × 3/4" × 46"
C	Top & Bottom	2 (plywood)	3/4" × 19" × 19"
D	Top & Bottom Banding	2	3/4" × 3/4" × 19"
E	Top Build-Up	2 (scrap plywood)	1/2" × 3/4" × 20 1/4"
F	Top Build-Up	2 (scrap plywood)	1/2" × 3/4" × 18 1/2"
G	Finished Top	1 (scrap plywood)	3/4" × 20 5/8" × 20 5/8"
H	Top Trim	4	Cut to fit
I	Pedestal Top	1 (plywood)	3/4" × 20 1/2" × 20 1/2"
J	Pedestal Bands	2	3/4" × 1 3/4" × 20 1/2"
K	Pedestal Bands	2	3/4" × 1 3/4" × 19"
L	Base Trim	4	Cut to fit
M	Coat Hook Rail	2	3/4" × 3 1/2" × 17 1/2"
N	Adjustable Shelves	3 (plywood)	3/4" × 18 7/8" × 18 7/8"
O	Shelf Banding	3	3/4" × 3/4" × 18 7/8"
P	Lazy Susan		

WOOD FINISHING PRODUCTS

Recommended Finish

Prep: Minwax® Pre-Stain Wood Conditioner (oil-based)
 Stain: Minwax® Wood Finish™, Weathered Oak
 Finish: Minwax® Fast-Drying Polyurethane, Satin

Alternate Finish

Prep: Minwax® Water Based Pre-Stain Wood Conditioner
 Stain: Minwax® Water Based Stain, Terracotta
 Finish: Minwax® Polycrylic® Protective Finish, Semi-Gloss

BEFORE YOU BEGIN

Good craftsmanship begins and ends with good work habits, so make the following steps part of your routine workshop practice. If you have any doubts or questions about how to proceed with a project, always discuss them with your shop instructor.

- Carefully and fully review plans and instructions before putting a tool to the project lumber.
- Work sensibly and safely. Wear safety goggles. Wear the appropriate respirator whenever making sawdust or working with thinners or other solvents.
- At the end of every work session, clean up your shop area and put away all portable tools.

CUTTING AND ASSEMBLY

1. Cut the three case pieces (A) to size (see Fig. 1).
 2. Rip the case banding (B). Make it oversized, approximately 13/16" square. Use a surface sander or planer to reduce it to a size that is slightly thicker than the plywood.
 3. Glue the banding to the case pieces. The two side pieces each receive one strip of banding. The back receives two.
- Woodworker's Tip:** *Be sure to wipe off any excess glue immediately. Dried glue will seal the pores of the wood and prevent it from absorbing your wood stain. Use an absorbent cloth soaked in water to remove the excess. Make sure the cloth is soaked (not just damp) with water. The water will dilute the glue, permitting the fibers of the cloth to absorb the glue with the excess water.*
4. Cut and band the front edge of the top and bottom pieces (C).
 5. Carefully sand all the edge banding to make it perfectly flush with the surface of the plywood. Be careful to not round over the banding's corners; keep them square and sharp.
 6. Mark out biscuit locations on the outside faces of the top and bottom. Center biscuits at 2" and 7" from each outside edge.

Woodworker's Tip: *When you will be laying out a number of pieces using the same measurements, use a story stick instead of measuring. Transferring marks from the story stick to the pieces guarantees perfect, consistent layout (see Fig. 2).*

7. Cut the biscuit slots, allowing the fence of the biscuit joiner to rest on the ends of the case sides and on the outside faces of the top and bottom.
8. Drill adjustable shelf holes in the case sides. There are a variety of ways to do this. One technique that works well is using a plunge router equipped with a guide bushing, allowing the guide bushing to seat in holes drilled into a thin plywood template to create the hole pattern. You can use a 1/4" or 5 mm router bit for this (see Fig. 3).
9. Sand the interior faces of all the pieces.

10. Assemble the case. Along with several bar clamps, use assembly squares and spring clamps to ensure the box is square (see Fig. 4). Remove excess glue as you did with the banding work.

11. Position the cabinet back side up on a bench and put the back in place. Mark out biscuit locations, starting 2" in from each end and approximately 6" on center between those points.

12. Cut biscuit slots in the case and back.

13. Glue and clamp the back to the case. Allow glue to dry.

14. Prepare the case for the top trim (H) by increasing the thickness of the top with the build-up strips (E and F). Cut 1/2" wide strips from scrap plywood. Glue and brad them to the case top. The purpose of the build-up is to create a 1/2" reveal between the edge of the chair rail and the bottom edge of the case top.

15. Cut the finished top (G) slightly oversize. Place the top, good side down, on a pad on the workbench. Position the cabinet on it and use eight #8 x 1-5/8" wood screws to secure it in place.

16. Trim the top flush to the case with a router fitted with a flush trim bit (see Fig. 5).

17. Attach a sacrificial fence to the miter saw. Set the saw at 45-degrees and cut through the fence. This fence will help prevent chipping on the back of the cut and also make it easier to align the parts for cut accuracy.

18. Cut two pieces of scrap top trim to 45-degrees. Check the fit of the pieces on each corner of the top to determine if you'll need to make any adjustments to the angle of the miter saw. If you do tweak the saw angle, you'll need to recut the sacrificial fence.

19. Cut the top molding pieces to rough length, about 23". Then cut a miter onto the right end of each piece.

20. Use a piece of mitered scrap to position one end of a piece of top molding precisely at a corner; then clamp it in place (see Fig. 6).

21. Where the other end of the molding runs out from the corner of the top, mark a cut line.

22. Carefully position the cut line against the left side of the kerf in the sacrificial fence and cut the piece to length. Check the fit on the case. Repeat for the remaining top molding pieces.

23. Cut the pedestal top (I) to size. Then glue the pedestal bands (K and J) to the bottom of the pedestal top, holding them flush with the outside edge (see Fig. 7).

24. Apply the base trim (L) to the pedestal using the same techniques as for the top trim. Note: any trim can be used. Adjust the width of the pedestal bands accordingly if you use a wider or narrower trim. Pieces look better when the base trim is wider than the top trim.

25. Center the Lazy Susan mechanism (P) on the pedestal. Mark the locations of the large access holes. Remove the mechanism and drill through the holes. This allows access to all the screws for final assembly.

26. Make the coat hook rail (M). Rout a decorative edge such as a chamfer or ogee on it.

27. Use a spacer stick to position the coat hooks 3/4" from the top of the rail. Put one in the middle and the other two 2-1/2" on center from the ends. Mark the screw hole locations and pre-drill them; you'll fasten the hooks to the rail after the staining and finishing are done.

28. Using a 3" wide spacer strip, position the coat hook rail 3" below the top trim and centered on the width of the case. Clamp the coat hook board in position and, from the inside of the case, pre-drill and drive screws. Use three #8 x 1-1/4" woodscrews (see Fig. 8).

29. Fasten the Lazy Susan mechanism to the pedestal. Then place the case on its top on a protective pad. Center the pedestal on the bottom of the case and, using the access holes in the pedestal, fasten the Lazy Susan to the case (see Fig. 9). Next, unfasten the Lazy Susan from the case and the pedestal so they can be stained and finished.

30. Make adjustable shelves by banding plywood with solid wood edging as you did on the case. Cut the shelves slightly smaller, no more than 1/8", than the inside dimensions of the case.

31. Sand the entire case, the pedestal, and the shelves in preparation for staining and finishing. The cork board will be adhered to the back of the case after the finishing is complete.

STAINING AND FINISHING

Woodworker's Tip: *Though you may be tempted to cut short your sanding, preparation, and application time, don't do it. These tasks are very important steps in obtaining a high-quality finish. Remember, it is the finish, just as much as the fit and smoothness of the parts, that will have an impact on how people judge your craftsmanship. To ensure an excellent result, follow the steps listed in this section and the instructions the finish manufacturer puts on its products.*

FINISHING TIPS

- Test the stains and finishes you are planning to use on scraps of wood. On the back of the scrap, mark the stain/finish combination and the type of wood. Allow all samples to dry thoroughly before making your final finish selection. Save your samples for quick reference on future projects.
- All stains and finishes must be allowed to dry thoroughly between coats. Remember that drying times can vary due to temperature, humidity, and other climatic conditions.
- If you have some leftover stain or finish, wipe the can rim so that stain or finish in the rim won't dry out and prevent the lid from forming a tight seal.

BEFORE YOU STAIN

Carefully sand the parts in the direction of the grain. Start with 120-grit paper and finish with 220-grit. Remove all the sanding dust. Then proceed with the stain and finish of your choice.

RECOMMENDED STAIN AND FINISH

1. Before applying Minwax® Wood Finish™, apply Minwax® Pre-Stain Wood Conditioner (oil-based), following the directions on the can. Applying a pre-stain conditioner will help to ensure even absorption of stain and prevent blotchiness.

2. Apply the Minwax® Wood Finish™ color you have chosen using a brush or a clean, lint-free cloth following the directions on the can. A brush will help you get the stain into the inside corners. Allow the Wood Finish™ to set for about 5 to 15 minutes, and then wipe off any excess. To achieve a deeper color, you may apply a second coat after 4 to 6 hours, repeating the application directions for the first coat. Allow the stain to dry for 24 hours before applying the protective clear finish.

Woodworker's Tip: *When wiping off stain, make certain that your last wipe with the cloth goes with the grain of the wood.*

3. Apply Minwax® Fast-Drying Polyurethane following the directions on the can. Stir the polyurethane thoroughly. Using a good quality, natural-bristle brush, apply a thin coat. Allow the first coat to dry 4 to 6 hours.

4. To apply a second coat, sand all surfaces lightly with 220-grit sandpaper. Dust off and wipe all surfaces with a cloth lightly dampened with mineral spirits. Apply a second coat and set the piece aside to dry for 4 to 6 hours.

5. If desired, apply a third coat following step 4. Allow the final coat to dry 24 hours before normal use of the piece.

ALTERNATE STAIN AND FINISH

Alt 1. Before applying Minwax® Water Based Stain, apply Minwax® Water Based Pre-Stain Wood Conditioner following the directions on the can. Applying it will help ensure even absorption of stain, prevent blotchiness that can occur, and minimize grain raise. Apply with a synthetic bristle brush. After 1 to 5 minutes, wipe off all excess conditioner using a clean, soft cloth. Wait 15 – 30 minutes, then use 220-grit sandpaper to sand off any grain raised by the conditioner. Do not use steel wool. Proceed to the staining within 2 hours.

Alt 2. Apply the Minwax® Water-Based Wood Stain you've chosen to the wood using either a synthetic brush or a clean cloth. Allow stain to penetrate no longer than 3 minutes. While stain is still wet, wipe off all excess with a clean cloth that's been lightly dampened with stain. Be sure to wipe in the direction of the grain. Allow the piece to dry for 2 hours before applying a second coat, if desired.

Alt 3. After allowing the piece to dry for at least 3 hours, apply Minwax® Polycrylic® Protective Finish following the directions on the can. Stir the can contents thoroughly before starting and periodically repeat the stirring during your work session. Do not shake.

Alt 4. Apply a thin coat of Polycrylic® with a high-quality synthetic bristle brush. Apply in one direction with the grain. Do not overbrush.

Alt 5. Allow the finish to dry a minimum of 2 hours. Then sand lightly with 220-grit sandpaper. Do not use steel wool. Thoroughly dust off and wipe all surfaces with a cloth lightly dampened with water.

Alt 6. Repeat step Alt 4 and Alt 5 for additional coats. Three coats are recommended. Allow the finish to cure for a few days before using the piece.

PRODUCT SAFETY

For your safety and the safety of those you work with, always read and follow the safety warnings that manufacturers print on their labels.

WARNING! Removal of old paint by sanding, scraping, or other means may generate dust or fumes that contain lead. Exposure to lead dust or fumes may cause brain damage or other adverse health effects, especially in children or pregnant women. Controlling exposure to lead or other hazardous substances requires the use of proper protective equipment, such as properly fitted respirators (NIOSH approved) and proper containment and cleanup. For more information, call the National Lead Information Center at 1-800-424-LEAD (in U.S.) or contact your local health authority.

DANGER: Rags, steel wool, other waste soaked with oil-based stains and clear finishes, and sanding residue may spontaneously catch fire if improperly discarded. Immediately place rags, steel wool, other waste soaked with oil-based products, and sanding residue in a sealed, water-filled metal container. Dispose of in accordance with local fire regulations.

When using oil-based wood finishing products:

CAUTIONS: CONTAINS ALIPHATIC HYDROCARBONS.

Contents are **COMBUSTIBLE**. Keep away from heat and open flame.

VAPOR HARMFUL. Use only with adequate ventilation. To avoid overexposure, open windows and doors or use other means to ensure fresh air entry during application and drying. If you experience eye watering, headaches, or dizziness, increase fresh air, wear respiratory protection (NIOSH approved), or leave the area. Avoid contact with eyes and skin. Wash hands after using. Keep container closed when not in use. Do not transfer contents to other containers for storage.

FIRST AID: In case of eye contact, flush thoroughly with large amounts of water for 15 minutes and get medical attention. For skin contact, wash thoroughly with soap and water. In case of respiratory difficulty, provide fresh air and call physician. If swallowed, call Poison Control Center, hospital emergency room, or physician immediately.

DELAYED EFFECTS FROM LONG-TERM OVEREXPOSURE.

Contains solvents, which can cause permanent brain and nervous system damage. Intentional misuse by deliberately concentrating and inhaling contents may be harmful or fatal.

WARNING: This product contains a chemical known to the State of California to cause cancer and birth defects or other reproductive harm.

DO NOT TAKE INTERNALLY. KEEP OUT OF REACH OF CHILDREN.

CONFORMS TO ASTM D-4326. Contact a physician for more health information.

When using water-based wood finishing products:

CAUTIONS: Use Only With Adequate Ventilation. To avoid overexposure, open windows and doors or use other means to ensure fresh air entry during application and drying. If you experience eye watering, headaches, or dizziness, increase fresh air, or wear respiratory protection (NIOSH approved), or leave the area. Avoid contact with eyes and skin. Wash hands after using. Keep container closed when not in use. Do not transfer contents to other containers for storage.

FIRST AID: In case of eye contact, flush thoroughly with large amounts of water. Get medical attention if irritation persists. If swallowed, get medical attention immediately.

WARNING: This product contains a chemical known to the State of California to cause cancer and birth defects or other reproductive harm.

DO NOT TAKE INTERNALLY. KEEP OUT OF REACH OF CHILDREN.

CONFORMS TO ASTM D-4326. Contact a physician for more health information.

FIG 1.

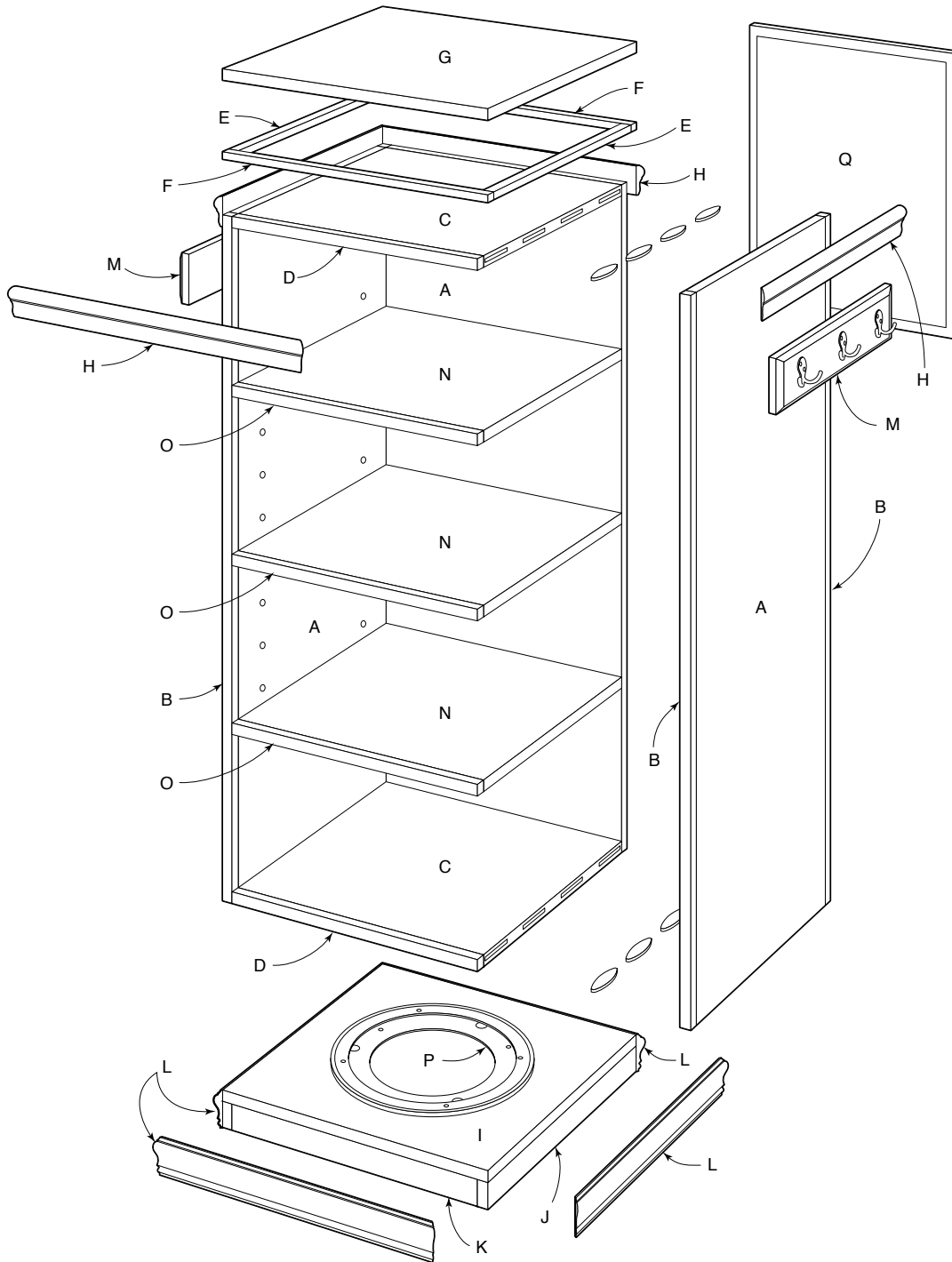

FIG 2.

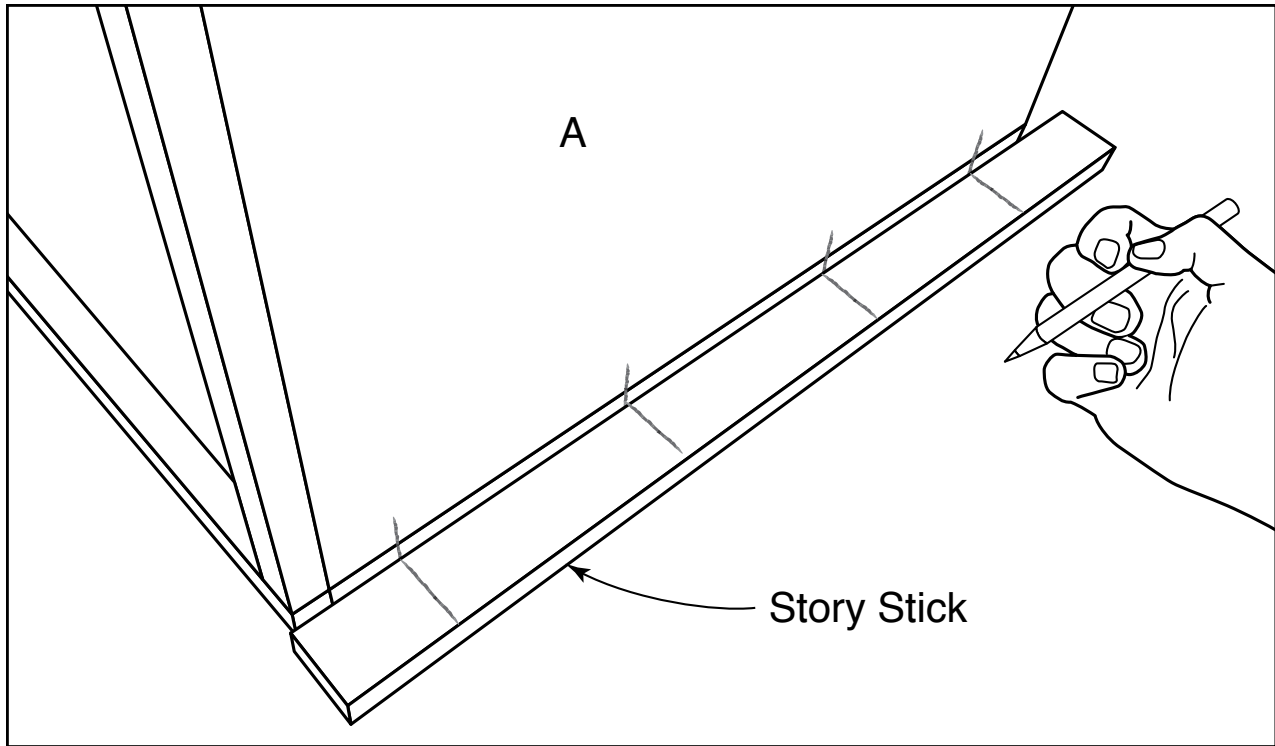

FIG 3.

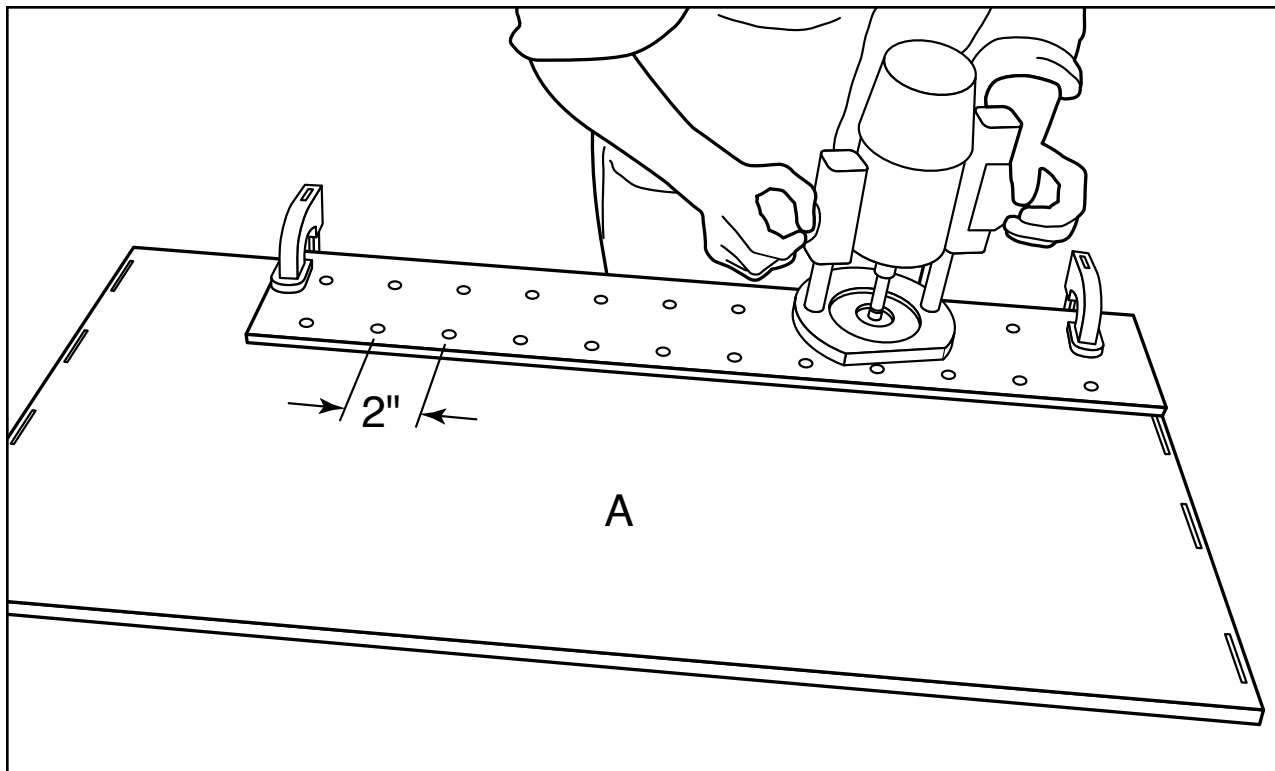

FIG 4.

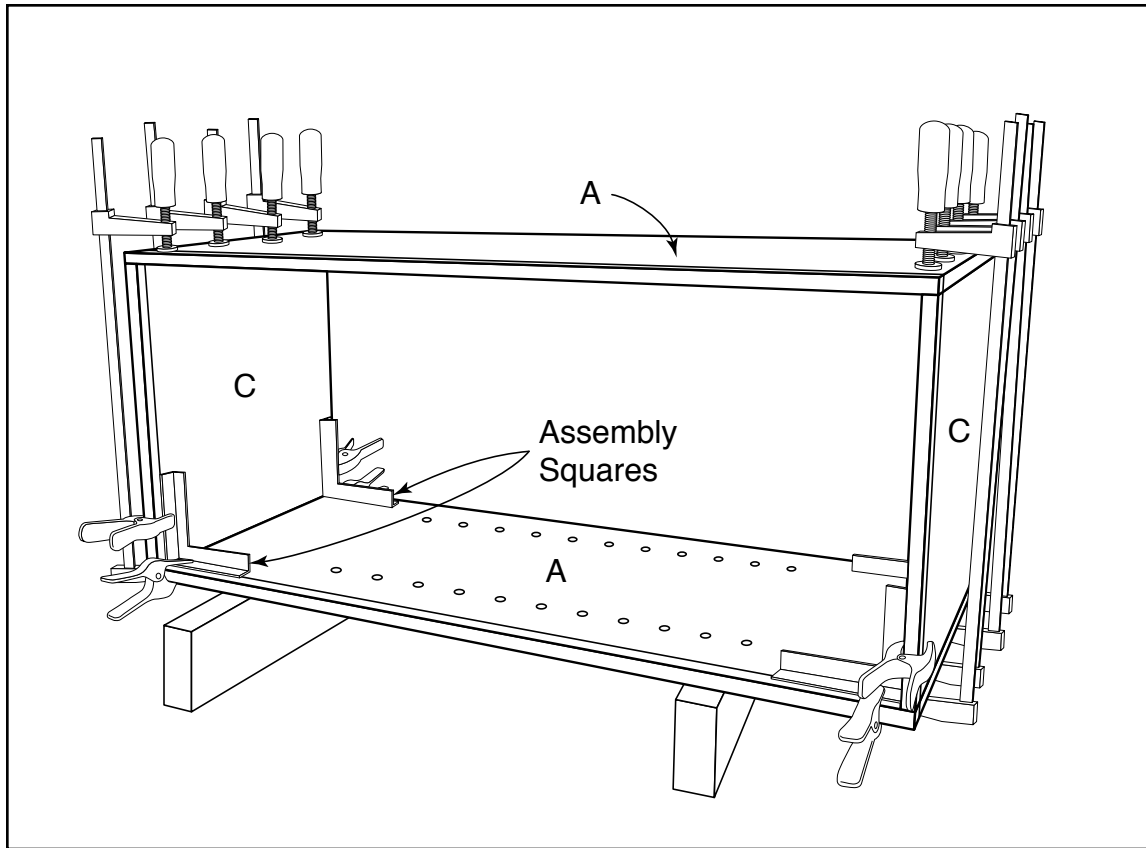

FIG 5.

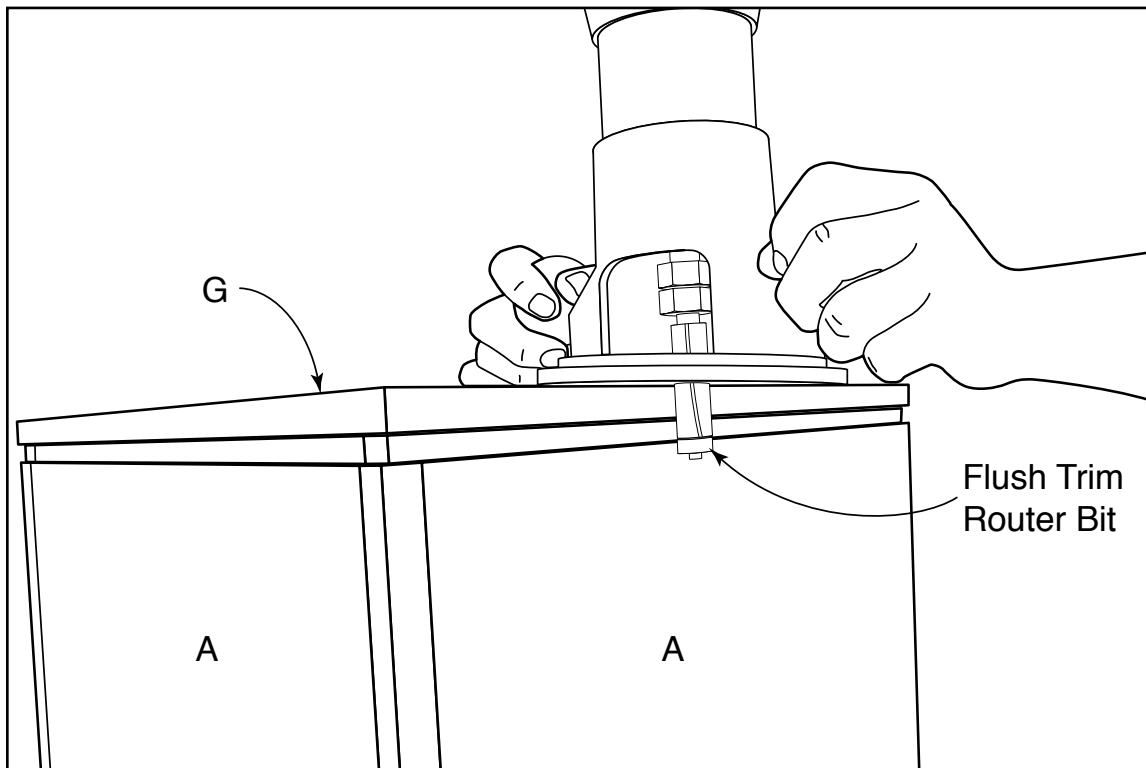

FIG 6.

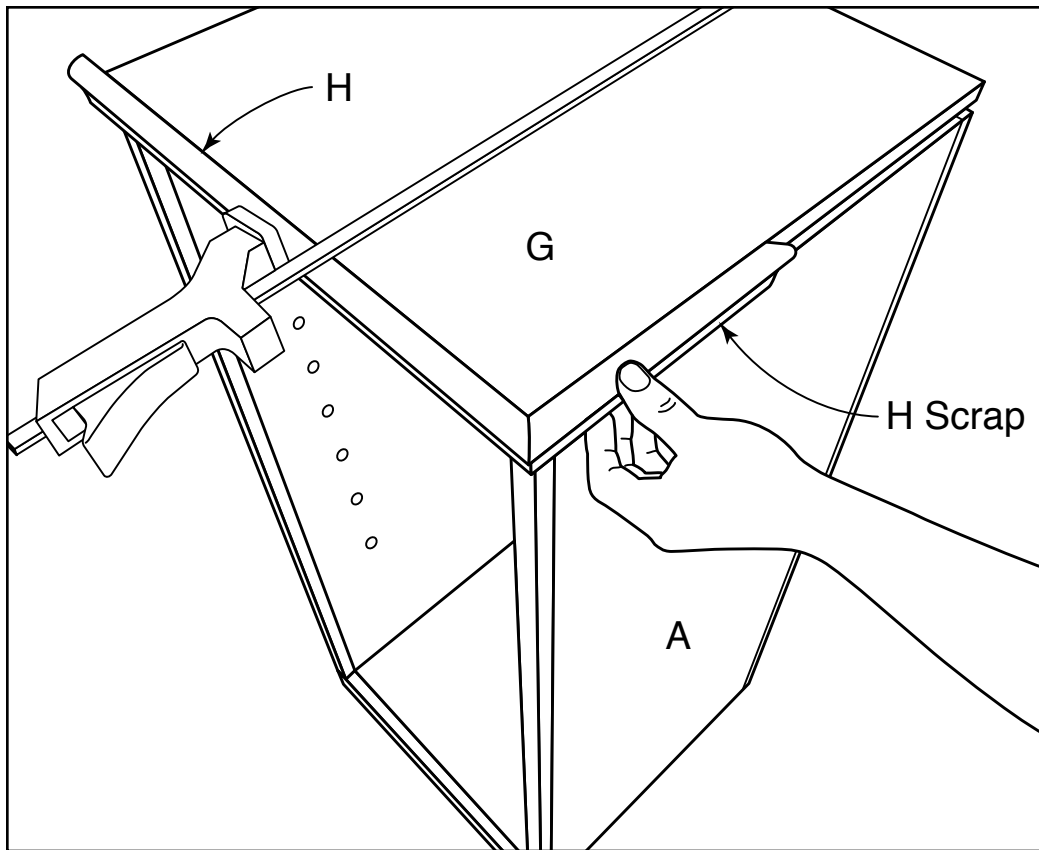

FIG 7.

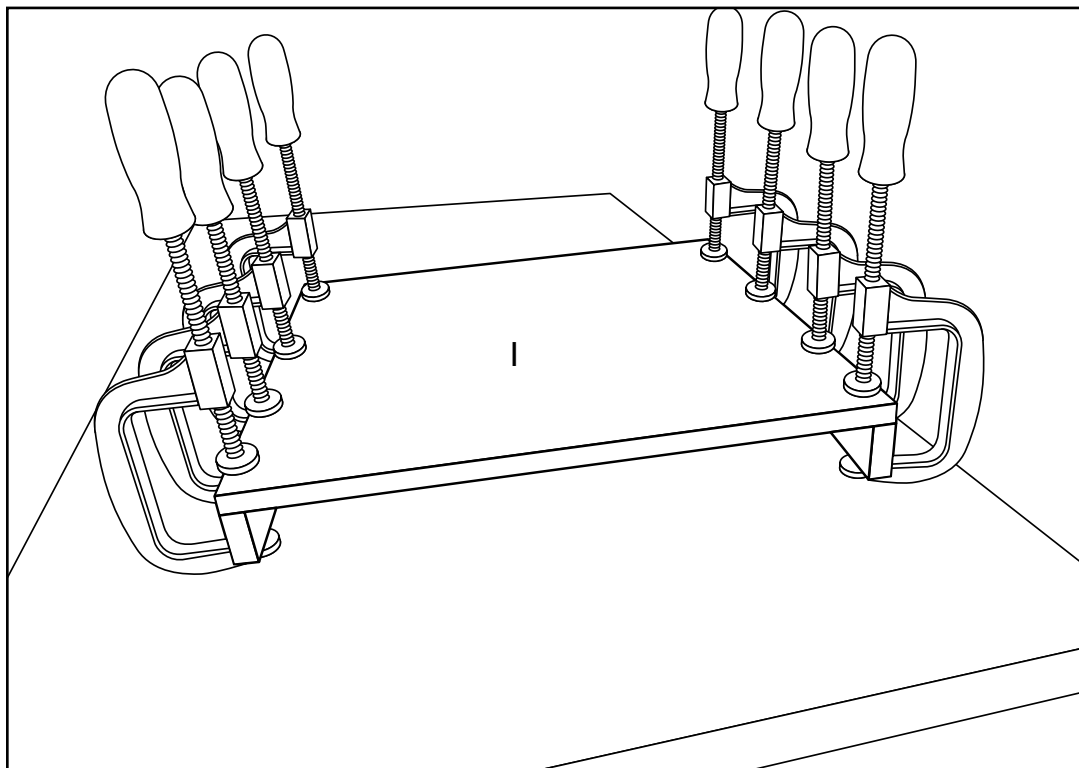

FIG 8.

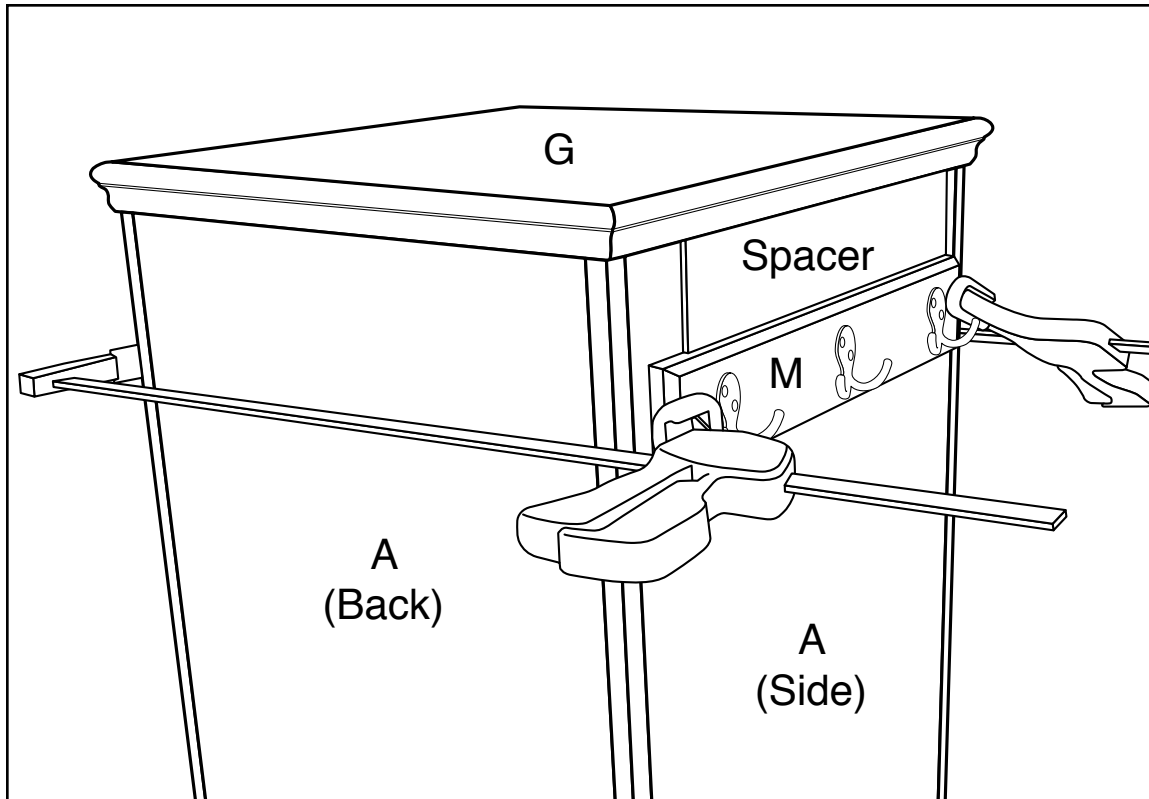

FIG 9.

