



WOODWORKS: ADVANCED PROJECT SHAKER WORKBENCH



Country-style furniture has been the most popular furniture in this country for decades. It is easy to understand why. Besides its look being visually pleasing and compatible with just about any home setting, it is also very functional. This handsome piece, which is inspired by the past, proves the point. Though the original served as a light-duty workbench in a Shaker community, its good looks makes this piece a welcome addition in just about any room. In a dining room, it will serve handily when entertaining and, if used in the living room, it is a conversation piece. Or you may prefer to simply use it in your workroom for light-duty tasks such as crafts and painting.

An early Shaker Seed Bench observed in New England inspired its design and our version will require you to execute a variety of woodworking skills. You may already possess some of the necessary skills while others may be new to you. Cutting and shaping the various members is, of course, routine woodworking. However, we have added some detailing – such as the fingerlap joints on the drawer cases which present the builder with the chance to practice – (and show off) fine woodworking craftsmanship.

You should approach a project of this dimension the same way a professional woodworker would. First, carefully study both the how-to-build instructions and the drawings. If you feel unsure of any of the details, do take the time to resolve those questions by first discussing them with your instructor. Take this suggested step before you even buy the materials for the project.

TOOLS REQUIRED

Hand

- Pencils, Handsaws
- Awl
- Assorted-Dia. drill bits
- Phillips screwdriver (medium), Router Table
- Ruler (zigzag or tape)
- Block plane
- Mallet
- Assorted chisels
- Square (combination or try)
- Hammer and 1/32nd nailset
- Assorted files
- Clamps; Hand screw, bar Hand screw and bar & C-clamps
- Sandpaper 80-grit through 220-grit

Power

- Table saw with dado head set
- Router, assorted cutters
- Planer
- Jointer
- Saws (band, radial arm)
- Sanders (stationary belt and portable belt, random orbit, pad)
- Drill press
- Portable electric drill with assorted bits
- Plate joiner with no. 20 biscuits
- Power screwdriver

BUILDING MATERIALS REQUIRED

See Shopping and Cutting Lists

WOOD FINISHING PRODUCTS

Finish Recommended for this Project

- Minwax® Pre-Stain Wood Conditioner
- Minwax® Wood Finish™
Ipswich Pine or other light finish
- Minwax® Fast-Drying Polyurethane®

Alternate Finishes

- Minwax® Water Based Pre-Stain Wood Conditioner
- Minwax® Water Based Wood Stain available in 50 custom-mixed colors and a White Wash Pickling Stain.
- Minwax® Polycrylic® Protective Finish
- Or, this one-step finish:**
Minwax® Express Color™

Miscellaneous

- Clean lint-free rags
- Paint thinner, if necessary
- Tack cloths
- Minwax® Wood Putty
(color to suit selected stain)
- Water-filled metal container with lid
(if oil finishes used)

BEFORE YOU BEGIN:

Craftsmanship begins and ends with good work habits. Make it your routine to:

- Adhere to all workshop safety rules.
- Read through all instructions carefully; this includes manufacturer instructions on product labels as well as the building information in plans with which you will be working.
- Give your tools and workshop the care they deserve.

A final reminder before starting this project: Take the time to discuss your project with your instructor. You will avoid frustration and wasted materials.

PROCEDURE

Construction begins by laying out the boards for rough-cutting to size. Take your time when doing this so as to avoid wasting costly materials. Lay out the boards for all the major carcass parts; you will cut the wood for the doors later.

Mark all parts for easy identity, before you do any cutting. Make sure you code each piece with its key letter; this prevents confusion later when all those parts are stacked in neat little piles of shorter-length pieces.

You are advised to work with the dimensions given on the drawing, since these closely replicate the piece studied in New England and are in accord with architectural standards.

START WITH THE CARCASS

1. Lay out the boards for the carcass sides and the top. Cut the boards for these parts slightly oversize and set them into separate piles, one for each side and a third pile for the top.
2. Position the boards for the top on your workbench and arrange them to achieve the most pleasing grain arrangement. When satisfied, using a pencil lightly draw a cabinetmaker's triangle across the three pieces (this step permits returning boards quickly to the desired arrangement, later).
3. Make the pencil marks along the abutting edges to indicate where the plate joiner is to plough the grooves and cut the grooves to suit the no. 20 biscuits.
4. Apply glue to mating surfaces for the first two boards, insert the biscuits and, using a rubber mallet, tap the boards together.
5. Working quickly, apply glue to the board edges that will mate for the second joint and assemble using biscuits.
6. Use at least three bar clamps to apply light pressure on this setup—just enough to achieve glue squeezeout along the joint lines. Then set the clamped-up section aside to dry overnight.
7. Repeat these steps for the two sections that will become the carcass sides.
8. Next day, starting with the top, remove the clamps and with a sharp, heavy-duty hand scraper, remove excess glue squeezeout from the surface. Do not try to get all of it, just the excess that protrudes above the surface.
9. Sand both sides of the top by first using a random orbit sander and 100-grit paper; then switch to a belt sander and 100-grit abrasive. Make sure you work the latter in a direction parallel to the wood grain. Sand both sides of each section to remove all traces of glue squeezeout and to ensure the joints being flush and smooth.

10. Switch to 120-grit sanding belts and repeat the smoothing on both sides.

11. Install 150-grit paper on your finishing sander and complete smoothing of the top.

12. Repeat the scraping and sanding steps for the two-carcass end sections (D).

13. Next, cut the top surround parts to size. Measure for the two end sections and the front piece (A1 & A2) and cut all three parts slightly overlong. You want to make sure you have some extra length for when you cut the miters to install this trim on the top.

14. Before adding the surround, position the top on your workbench and lay out for the dados and edge rabbet that will receive the back-splash parts (B & C).

15. Insert a 3/4-in. dia. straight cutter in the router and use a clamped-on straight edge to guide your router as you cut these dados and the edge rabbet at back.

16. Cut the “backsplash” parts to their finish width and slightly overlong.

17. Temporarily assemble these three parts in the top so you can mark each for the exact length to cut them.

18. Cut the three parts—back and two end returns—to exact length.

19. Then lay out for the rounded corners on the two end returns and cut them to shape using scroll or band saw.

20. Sand the parts following the sequence spelled out in steps 9, 10 and 11. Do **not** assemble the backsplash parts to the top at this time.

21. Lay out and plough the edge rabbets to receive the cabinet back on the inside back edges of the carcass sides.

22. Carefully lay out and install the four shelf cleats at this time. Use carpenter's glue and 1-1/2 in. finishing nails; set the nailheads below the surface and fill the recesses with Minwax Wood Putty®.

Note: Since Minwax Wood Putty® does not accept stain, make sure you pick a putty color that closely matches the stain you plan to apply. Sand smooth and dust off.

23. Next, after double-checking the overall dimensions for your top, measure and cut the pieces for the rails.

24. It goes a lot easier at this stage if you have help assembling the carcass. Lacking assistance requires you to enlist the aid of clamps as a “third hand.” One way is to position a bar clamp with its bar resting on the worktable while its jaws hold a carcass leg upright. Then use a handscrew to secure the bar to the worktable.

25. Assemble the carcass using carpenter's glue and fasteners as indicated in the drawing. When all is assembled, check all corners for squareness—i.e., from top to sides, and from sides to front, etc.

26. When satisfied that the carcass is square, with bar clamps apply pressure across all glued joints to close all joints and achieve slight glue squeezeout. Let this setup rest 24 hours before proceeding.

27. Next day, install the top using glue and screws, as shown in the drawing. Put a dab of glue over each screwhead and tap in the dowel plugs to conceal screwheads. Note that the plugs are not necessary for the screws along the back edge; these will be concealed by the backsplash.

28. Squirt glue into the edge rabbet and dados in the top and spread it evenly. Install the rear backsplash, followed immediately by the end returns. Make sure you apply glue to the joints between the end returns and rear splash.

29. Use bar clamps to clamp the rear splash firmly to the top; make sure it is square to the surface of the top.

30. Next, secure the end returns by drilling undersized lead holes at an angle through the rounded front ends of the returns; secure the front ends with 2-in. finishing nails.

31. Immediately go to the rear of the piece and bore lead holes through the rear splash and drive three 2-in. finishing nails through the rear splash and into each end return.

32. Set all the nails slightly; fill recesses with Minwax Wood Putty® (see Note regarding putty in previous step number 22). Leave the clamps on the backsplash overnight.

THE DRAWERS & DRAWER CASES

Cabinetmaker's Tip: *The drawer cases on this cabinet give the builder the opportunity to create an out-of-the-ordinary joint, one that is sure to draw admiring comments. The joint used on the drawer case is the fingerlap joint, due to the great amount of gluing surface, is an incredibly strong joint. Also called the box joint, it is a joint that, when executed properly, will never open. A fingerlap joint will be even stronger by boring through the "knuckles" and inserting a glued-in length of dowel. Though the latter is not a necessary step, you should know about it. If you decide to add the dowel, make sure you use only a very sharp wood-boring bit to bore the lead hole: do not use a high-speed twist drill. The end lap piece is fragile when exposed to drilling and can easily chip out: a twist bit is likely to cause such a break. Since a fingerlap joint looks best when the fingers are of a width equal to one-half the thickness of the stock being joined, the notches and fingers here are cut to 3/8-in. width. Install a dado head on the saw set to cut a 3/8-in.-wide notch: See the drawings for the suggested technique for making this cut.*

1. Cut the parts for the 1/4-in. plywood plates that serve as nailing cleats for the drawer half-box. Carefully lay out these parts and install them using carpenter's glue and 1-1/4 in. brads.
2. Cut Parts O and P for both drawer cases. Put I.D. marks on these pieces (i.e., box 1, and box 2) so parts do not become mixed during the cutting and assembly steps.
3. Lay out for cutting the fingerlap joints for both drawer cases; refer to drawing if this is your first time making this joint. **Note:** Many cabinetmakers cut the fingerlap notches to a width equal to stock thickness. However, the joint is more attractive, and the glue area increased substantially, if the notches equal half the stock thickness. Thus, the suggested fingerlap-width in this wood is 3/8 in.
4. Cut notches using the table saw technique and jig shown in the drawing.
5. After cutting the joints, test-fit them. Make light pencil marks where any knuckle may be tight (in order to interlock joint). Use a smooth file and sandpaper if necessary on the tight knuckles to assure the joint going together easily and tightly. Repeat steps for the second case. **Note:** Take extra care when hand-shaping and fitting these joints because they can be easily broken.
6. When satisfied with the joints, install the half-cases on the cabinet. Apply a small amount of glue to the mating knuckle surfaces and join the first drawer-case bottom to its mating side.
7. Immediately install the half-box on the cabinet. To do it, carefully squirt some glue along the plywood-cleat edges—where the bottom and side will abut them. With case held securely in position, drive-in 1-1/2 in. finishing nails, through predrilled holes angled through

drawer case side into the top. Check box to be sure it is still square and secure with angled nails through the bottom and into the cabinet side. Wipe off all glue squeezeout with a dampened cloth. Repeat to install second case.

8. Measure to determine size to cut case back (I) which should be flush with bottom and side and abutting the plywood cleats on top and cabinet. Install backs using glue and 1-1/2 in. finishing nails through drawer case. Bore lead holes for the nails to prevent any splitting of the case stock.

The Drawers

The small drawers go together using conventional drawer assembly. Since your cabinet dimensions may vary, even slightly, from the dimensions shown on the drawing, cut the drawer parts only after taking measurements directly from the just-finished drawer cases. Do as the professionals do and mark each drawer to mate with its own drawer case, then use I.D. marks to keep each drawer paired with its case.

Because the drawers are so small, the hardwood stock for the sides is planed to 3/8-in. thickness.

1. Cut all parts for the drawers and sand pieces smooth, to the 150-grit stage. Make two piles of parts; each one containing a front, false front, two sides, back and a bottom. Keep parts in two separate piles.
2. Lay out for the bottom-holding grooves in drawer sides. Note that this groove in the sides aligns with the lower edge of the false drawer front. Install dado cutter to cut a 1/4-in.-wide dado on the table saw. Set dado cutter to plough 3/16-in.-deep grooves. Lock the rip fence at correct distance from dado cutters and plough the grooves.
3. Finally, lay out the dadoes in the sides to receive the backs. Take care at this point to assure that you cut these dadoes in the correct end of each side. Remember that the dadoes in opposite sides must be mirror image. Use the miter gauge and hold the workpiece securely as you plough the dado.
4. Build one drawer at a time. Start by fastening the false front (S) to the back of the drawer front; install with glue and 3/4-in. brads.
5. Align one side with front and attach with glue and 1-1/4 in. brads.

Cabinetmaker's Tip: *Here's the easy way to make certain the grooves for the bottom will be aligned with each other and with the bottom edge of the false front. Cut a 2 x 3-in. piece of the 1/4-in. plywood used for the bottom from scrap. Clamp the first side in a bench vise, front end up with groove toward you. Put the scrap piece into the groove so it projects slightly above the end—just enough to rest the false front against before nailing the two pieces together. Use the scrap to assist alignment of the second side too.*

6. With both sides attached, slide the bottom into the grooves until it abuts the back of the drawer front. Do not glue-in the bottom.
7. Put glue in both dadoes in the drawer sides and on the drawer back ends only. Slide the back down the grooves until it abuts the plywood bottom. The back should be flush at the top with the drawer sides. When all is in alignment, drive 3/4-in. nails through the bottom up into the drawer back. Repeat to assemble the second drawer.
8. Locate the knob positions, tap and indent with an awl and bore pilot holes for the screws. Install the knobs.

THE DOORS

To make the doors, follow the same procedure that was used to edge-join the boards for the top and carcass sides. As before, finish door edge-joining step by sanding them on both sides to the 150-grit stage.

1. Check the actual dimensions of the two door openings in the cabinet you just assembled; size and cut your pair of doors to suit the openings in your cabinet.
2. Lay out for the hinges on the door stiles, see drawing for exact location. Using a sharp 3/4-in. chisel and mallet cut the mortises in doors; install hinges with screws provided.
3. Lay out the locations for the hinges on the door stiles by carefully measuring the hinges installed on doors. Locate hinges on stiles so that door, when hung, will have approximately 1/8-in. gap at both top and bottom. Mortise the door stiles to receive the hinges. (Do not worry about the door width at this time; you can plane it to fit later.)
4. Install the first door by holding it in place (i.e., top hinge leaf in appropriate mortise) with one hand, while driving the first screw home using an electric screwdriver. After the first screw is seated, the job goes quickly. Finish by driving all screws through both hinge leaves.
5. Repeat steps to hang the second door. If necessary, plane door edges at the center stile, as needed, to achieve proper door operation. Sand smooth to finish.
6. Lay out for the wooden knobs and latches and bore the holes for them.
7. Hand fashion the pair of latches and sand them smooth. Install on cabinet as shown in drawing.
8. Lay out and install the pair of magnetic catches.
9. Cut, and install the shelf. You can permanently install the shelf parts using glue and nails, but it is probably wiser to just set the shelves on the cleats. This way, should you want to change the shelf height later, you will be able to do so with minimal effort.
10. Install the 1/4-in. plywood back panel using 1-1/4 in. brads, but no glue (in case you ever have to remove back).

Cabinetmaker's Tip: *The finishing steps will be easier and go a lot faster if you leave the back off until all finishing is completed.*

FINISHING THE BENCH

Some woods, including pine, have a tendency to take stain unevenly, thus making “blotching” a possibility. You can avoid undesirable blotches by using a pre-stain conditioner. Make sure you use an oil-based Conditioner when using oil stain. When using water-based stains, always use a pre-stain wood conditioner. This will allow grain to raise and be sanded prior to applying the stain color. The first finish outlined below is an oil-based finishing system.

Before Staining

1. Remove the doors from the cabinet and take off all hardware, knobs, etc.
2. Run your hands over all cabinet surfaces to check for smoothness; sand where necessary using 150-grit paper wrapped around a soft backup block. Thoroughly dust off the piece and wipe carefully with a tack rag to remove all traces of dust.
3. Apply Minwax® Pre-Stain Wood Conditioner: brush it on evenly. Work quickly, maintaining a “wet edge” to avoid streaks or overlaps. Allow it to penetrate for 15 minutes.

4. After 5 minutes, use a clean, lint-free cloth to remove any excess Conditioner remaining on the surface. Proceed to the staining within 2 hours.

Staining

1. Apply Minwax® Wood Finish™ using a natural bristle brush.
2. Bring a “loaded” brush to the surface and apply stain with across-the-grain strokes, followed immediately with brush strokes parallel-to-the grain.
3. Work a small, manageable area at a time and apply the stain to maintain a wet edge.
4. Allow the stain to remain on the surface for 5 to 15 minutes, time depending upon degree of stain darkness desired.
5. Wipe off all excess using a clean lint-free cloth. Make the final wiping pass in a with-the-grain direction.
6. Repeats these steps on all sections of the cabinet, inside and out.
7. To darken color, apply a second coat after 4 to 6 hours. Do not sand between the two stain coats.

USEFUL FINISHER'S TIPS

- You can slightly round or “break” sharp edges on raw wood by using 100-grit paper in the pad sander. For a more pronounced rounding over, round the edges with the router and a 1/4-in. rounding-over bit.
- To achieve an “antique” look when using a Minwax® Wood Finish™ stain, don't break the edges until after the stain has been applied and dried. This will allow small amounts of wood to show through, creating the appearance of worn spots.
- Sand raw soft woods to at least the 150-grit level; use even higher grit abrasives for hardwoods such as walnut and birch.
- Allow all stains and finishes to dry thoroughly between coats. Sanding between coats is done with 180-grit to 220-grit sandpaper, the grit getting finer after each succeeding coat.
- Apply water-based finishes, such as Minwax® Polycrylic®, with quick, with-the-grain strokes.

TOP COATING

The choice here is Minwax® Fast-Drying Polyurethane which is ideal for use on furniture because it provides a hard, durable finish. It is available in gloss, semi-gloss and satin sheens, with the latter being the best choice for this reproduction since it closely simulates the hand-rubbed look of old.

No matter which finish you opt to use, it is a good idea to open windows to ensure good air circulation and ventilation.

1. Allow the Minwax® Wood Finish™ stain to dry for at least 24 hours.
2. Stir the can contents thoroughly before starting (periodically repeat the stirring during your work session).
3. Use a natural bristle or foam brush to apply the first coat of Polyurethane. Work a small area at a time so you can maintain a wet edge at all times. Work quickly and make the final strokes in a with-the-grain direction.
4. Allow the finish first coat to dry overnight then sand lightly using 220-grit sandpaper wrapped around a soft backup block. Thoroughly dust off and wipe carefully with a tack cloth to remove all traces of dust particles.

5. Repeat application steps and apply the second coat.
6. For superior results, repeat above steps to apply a third coat of Minwax® Fast-Drying Polyurethane. Allow to dry overnight before reinstalling doors and hardware. Complete your cabinet by installing its back.
7. Allow the piece to rest for 1 week before putting it into service.

ALTERNATE STAINS/FINISHES

Water-Based Stain

BEFORE STAINING

1. Run your hands over the cabinet surfaces to check them for smoothness; sand where necessary using 150-grit paper wrapped around a soft backup block. Dust off the piece and wipe thoroughly with a tack rag. (Do not use steel wool to “sand.”)
2. Apply Minwax® Water-Based Pre-Stain Wood Conditioner. Work quickly, brushing it on evenly while maintaining a wet edge, to avoid streaks or overlaps. Allow Conditioner to penetrate for about 5 minutes.
3. After 5 minutes, use a clean, lint-free cloth to remove any excess Conditioner remaining on the surface. Allow 15-30 minutes before proceeding, but make certain you do follow with the next step, staining, within 2 hours.
4. Finally, check surfaces for whiskers that may have been raised. If you do find any, smooth them off using 180-grit (or finer) sandpaper wrapped around a soft backup block. Rub lightly then remove all sanding dust with brush and tack cloth.

STAINING

1. Start by opening the Minwax® Water-Based Wood Stain and, with a clean stick, stirring its contents thoroughly. Note: To avoid any chance of pigment settling during your staining operation, it is recommended that the stirring be repeated every so often during the staining step.
2. Apply the Stain using a nylon/synthetic brush, foam brush, staining pad or rag. Since Stain should be left on the surface for a relatively short period—about 3 minutes—work a small area at a time. While the Stain is still wet, remove any excess with a clean, lint-free cloth lightly dampened with Stain. Make the final wipe-off in a parallel-to-grain direction. Use light to medium pressure to ensure even color penetration.
3. **NOTE:** Should you have any uneven color penetration, immediately re-wet the surface with additional Stain and work it into the surface using either a rag or brush. Use light pressure over the dark and light areas until they blend together.
4. To increase color intensity, allow the first coat to dry 2 hours, then repeat the staining step.

Finisher's Tip: No matter what clear finish you are working with, the job is certain to turn out better when you use a strong light. An inexpensive photo lamp is ideal. To ensure finding any missed spots, position the lamp so its beam of light strikes the surface at a 45-degree angle to your line of vision. A missed spot will be flat, there will be no reflection. Move the lamp about as you move from one surface to the next to maintain the strong reflecting angle.

FINAL STEP

Applying Clear Finish

1. Open the can of Minwax® Polycrylic® Protective Finish and stir well. Do not shake Polycrylic®. Note: Periodically repeat the stirring during the finish application. The finish appears milky in the can but will dry crystal clear.
2. Apply Polycrylic® with a high-quality synthetic bristle brush. For best results, apply a thin first coat in the direction of the grain. Do not overbrush.
3. Allow the first coat to dry at least 2 hours, then sand smooth with 220-grit paper. Remove all dust with a tack rag.
4. Apply the next coat; let it dry 2 hours.
5. Apply the final coat.

Although the surface will be ready for light handling in 3 hours, allow the cabinet to cure for several days before reinstalling the doors and hardware, and putting the cabinet into service. Maximum durability will develop after 4 days.

ALTERNATE ONE-STEP FINISH

Minwax® Express Color™

This finishing technique, with a combined wiping stain and protective finish, is an easy one to use. Yet, it permits you to achieve a handsome hand-rubbed look in just a couple of hours. Use it only on raw wood or over previous coats of Minwax® Express Color™.

1. Sand surface smooth, to the 150-grit stage. Dust thoroughly and remove all dust with a tack cloth.
2. Shake the tube of Express Color™ vigorously for about 15 seconds. Then to assure your satisfaction with the color, apply some stain to an out-of-sight test area, such as a shelf underside.
3. Liberally apply Express Color™ using a clean, soft cloth or foam brush.
4. Allow to penetrate, then remove excess by wiping lightly with a clean soft cloth.
5. Two coats are best: Wait a minimum of 1 hour and apply the second coat in the same manner as the first coat. Extra coats may be applied if increased sheen and deeper color are desired.
6. For additional surface protection, wait 3 hours after second stain application and wipe on a coat of Minwax® Express Clear or Polycrylic®.
7. Immediately after each use, tightly close the tube.
8. Cleanup is with soap and water.

CLEANUP TIPS

- Clean all brushes used for water-based finishes immediately after use with warm soapy water.
- If you have product left over, wipe the can rim to remove all product in the rim. Liquids left in the rim can dry out and prevent the lid from forming a tight seal.
- Clean all brushes used for oil-based finishes with mineral spirits.

Product Safety

DANGER! HARMFUL OR FATAL IF SWALLOWED.

SKIN IRRITANT. COMBUSTIBLE.

KEEP OUT OF REACH OF CHILDREN.

WARNING! Removal of old paint by sanding, scraping or other means may generate dust or fumes that contain lead. Exposure to lead dust or fumes may cause brain damage or other adverse health effects, especially in children or pregnant women. Controlling exposure to lead or other hazardous substances requires the use of proper protective equipment, such as properly fitted respirator (NIOSH approved) and proper containment and cleanup. For more information, call the National Lead Information Center at 1-800-424-LEAD (in U.S.) or contact your local health authority.

VAPOR HARMFUL. Use only with adequate ventilation. To avoid over-exposure, open windows and doors or use other means to ensure fresh air entry during application and drying. If you experience eye watering, headaches or dizziness, increase fresh air supply or wear respiratory protection (NIOSH/MSHA TC23C or equivalent), or leave the area.

Avoid contact with eyes and skin.

Wash hands after using.

Keep container closed when not in use. Do not transfer contents to other containers for storage.

DO NOT TAKE INTERNALLY.

FIRST AID. In case of eye contact, flush thoroughly with large amounts of water for 15 minutes and get medical attention. For skin contact, wash thoroughly with soap and water. In case of respiratory difficulty, provide fresh air and call physician. If swallowed, get medical attention immediately.

DELAYED EFFECTS FROM LONG-TERM OCCUPATIONAL OVEREXPOSURE.

Contains solvents that can cause permanent brain and nervous system damage. Intentional misuse by deliberately concentrating and inhaling the contents may be harmful or fatal.

Safe Disposal of Rags & Waste

Please be mindful of the safe way to dispose of used rags and other finishing materials waste. Remember that rags, steel wool and other waste soaked with oil finish, mineral spirits, turpentine and the like may spontaneously catch fire if improperly discarded.

Always place these items in a water-filled metal container immediately after use. Tightly seal the container and then dispose of it in accordance with local fire regulations. Be sure to keep the container out of reach of children.

Created for GW&J and Minwax® by Harry Wicks Woodworks, Catchogue, NY 11935 ©March 2000

WORKBENCH SERVER

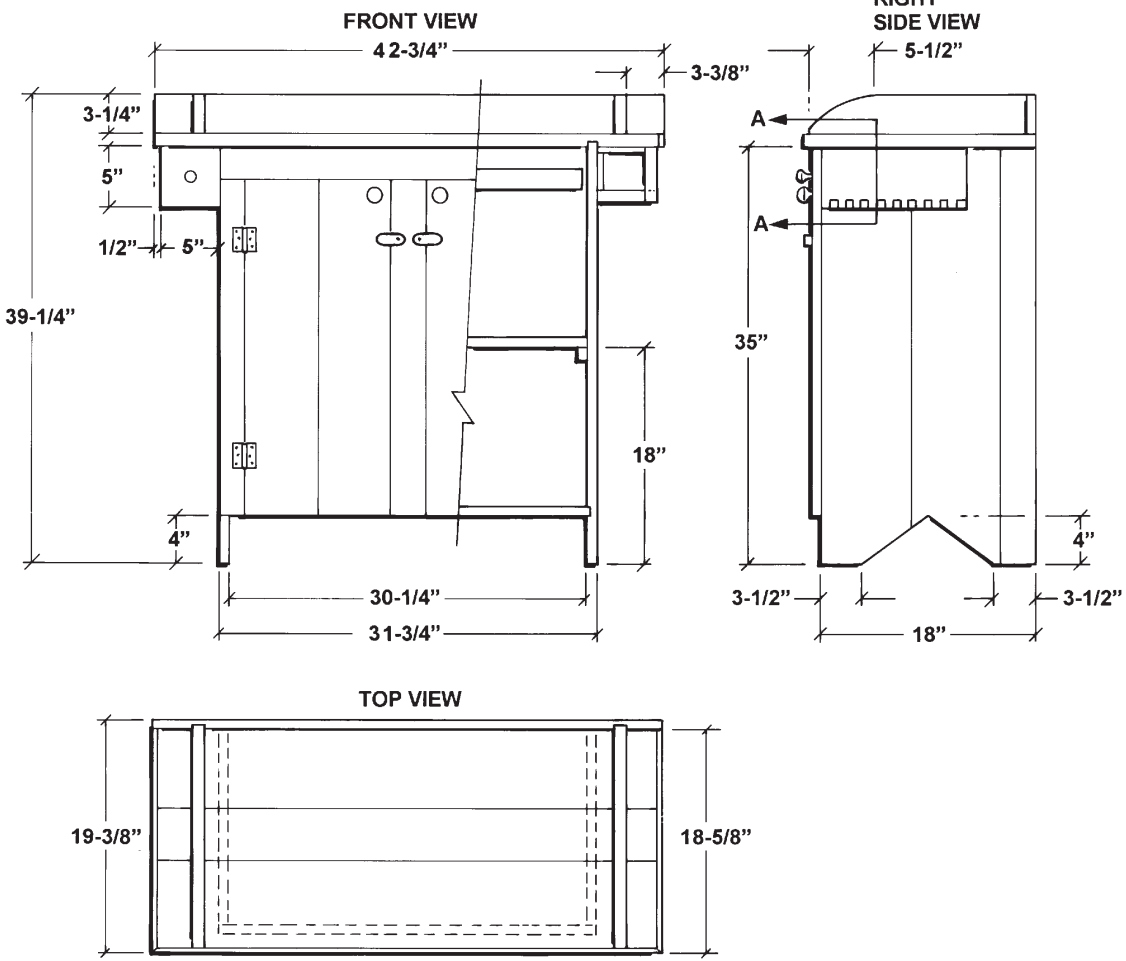

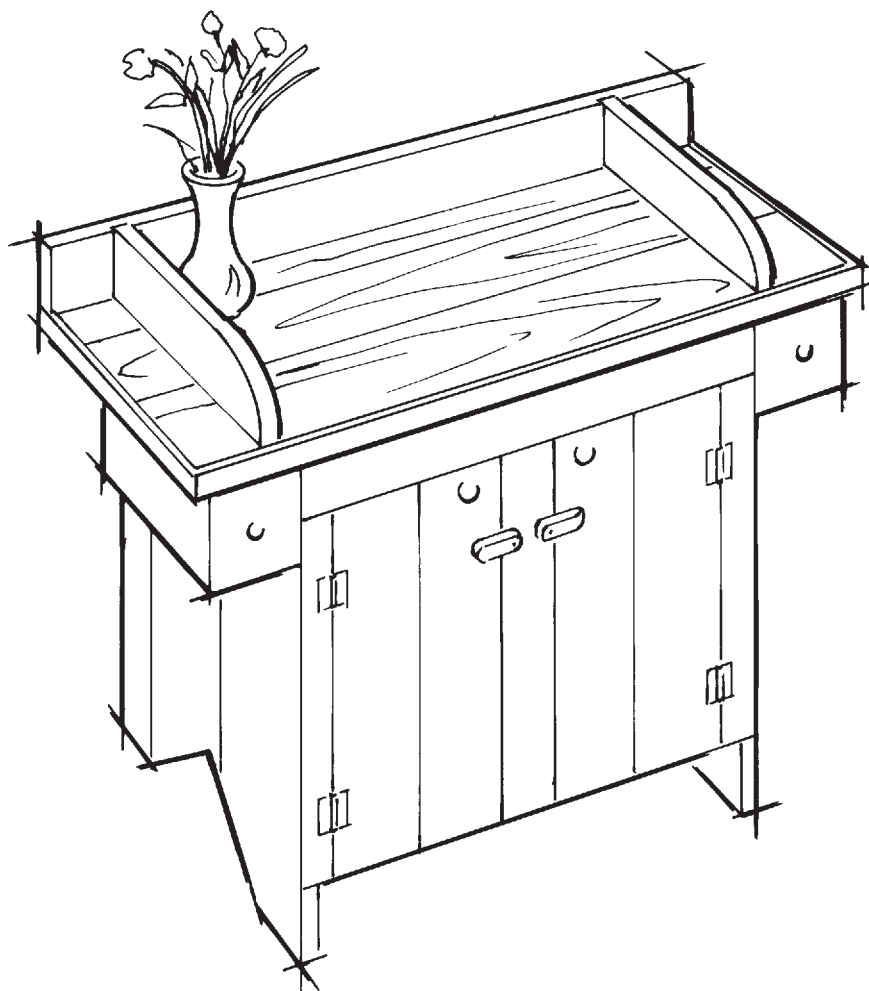

FINGERLAP JIG

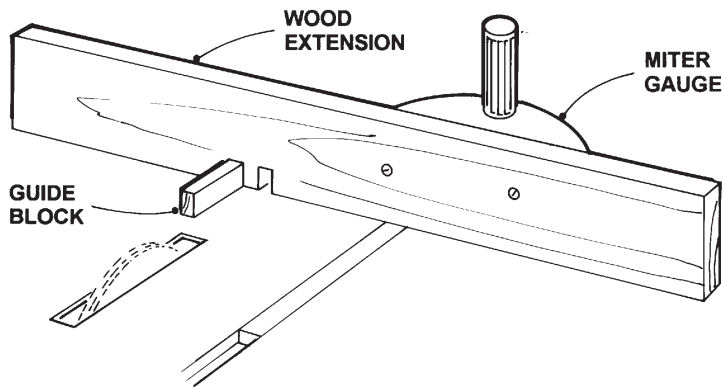

DRAWER CASE DETAIL

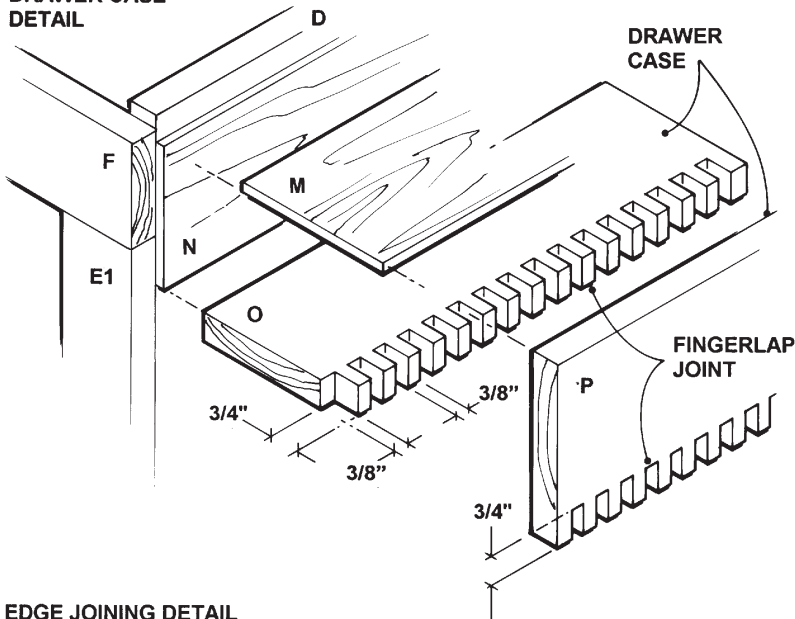

EDGE JOINING DETAIL TOP SHOWN

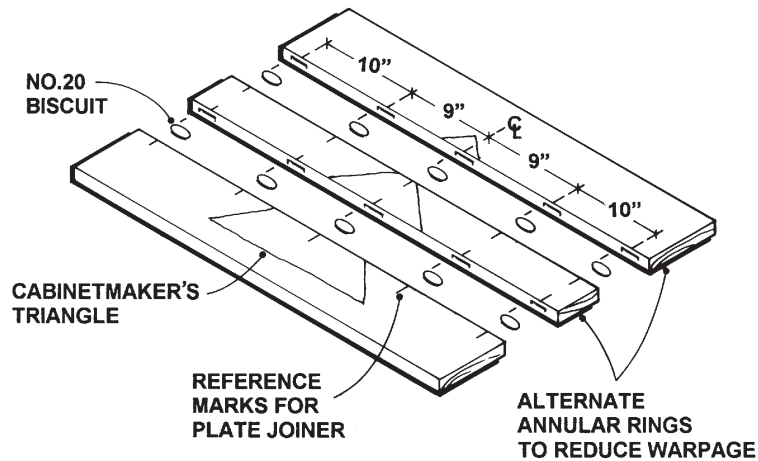

STEP 1.

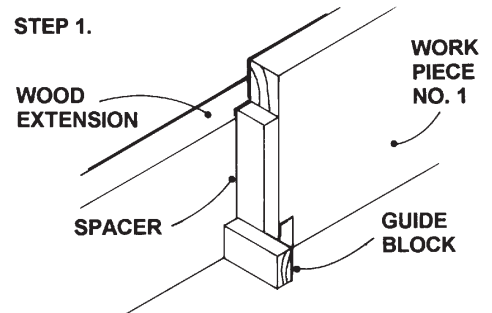

Step 1: Cut a spacer strip with dimensions that equal the groove width and insert it between guide block and 1st workpiece. Then, while holding the workpiece firmly, make the first cut.

STEP 2.

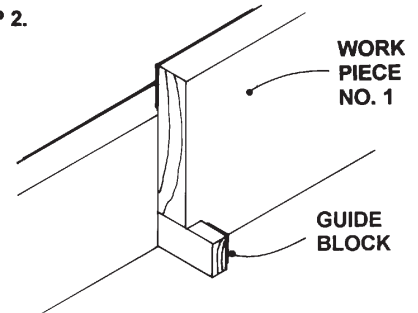

Step 2: Remove the spacer and move the workpiece over until it rests snugly against the spacer block.

STEP 3.

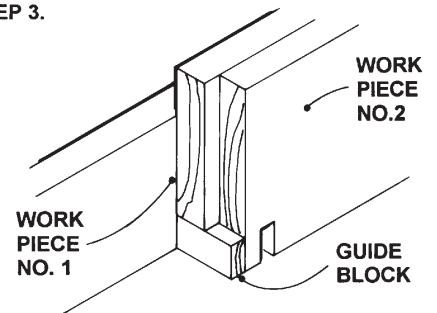

Step 3: Butt the 2nd workpiece tightly against the guide block, as shown. Then make a cutting pass to form the notch in both pieces simultaneously.

STEP 4.

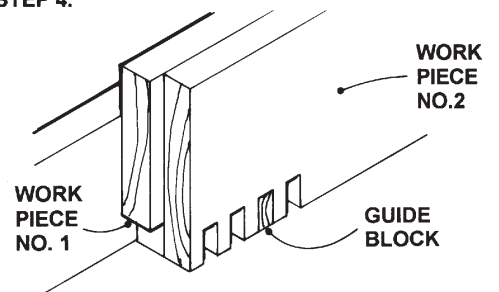

Step 4: Continue making cuts by placing the last notch cut over the guide block to position the boards for the next cut. Note: To ensure boards staying aligned together throughout the cutting process, use small c-clamps, if necessary.

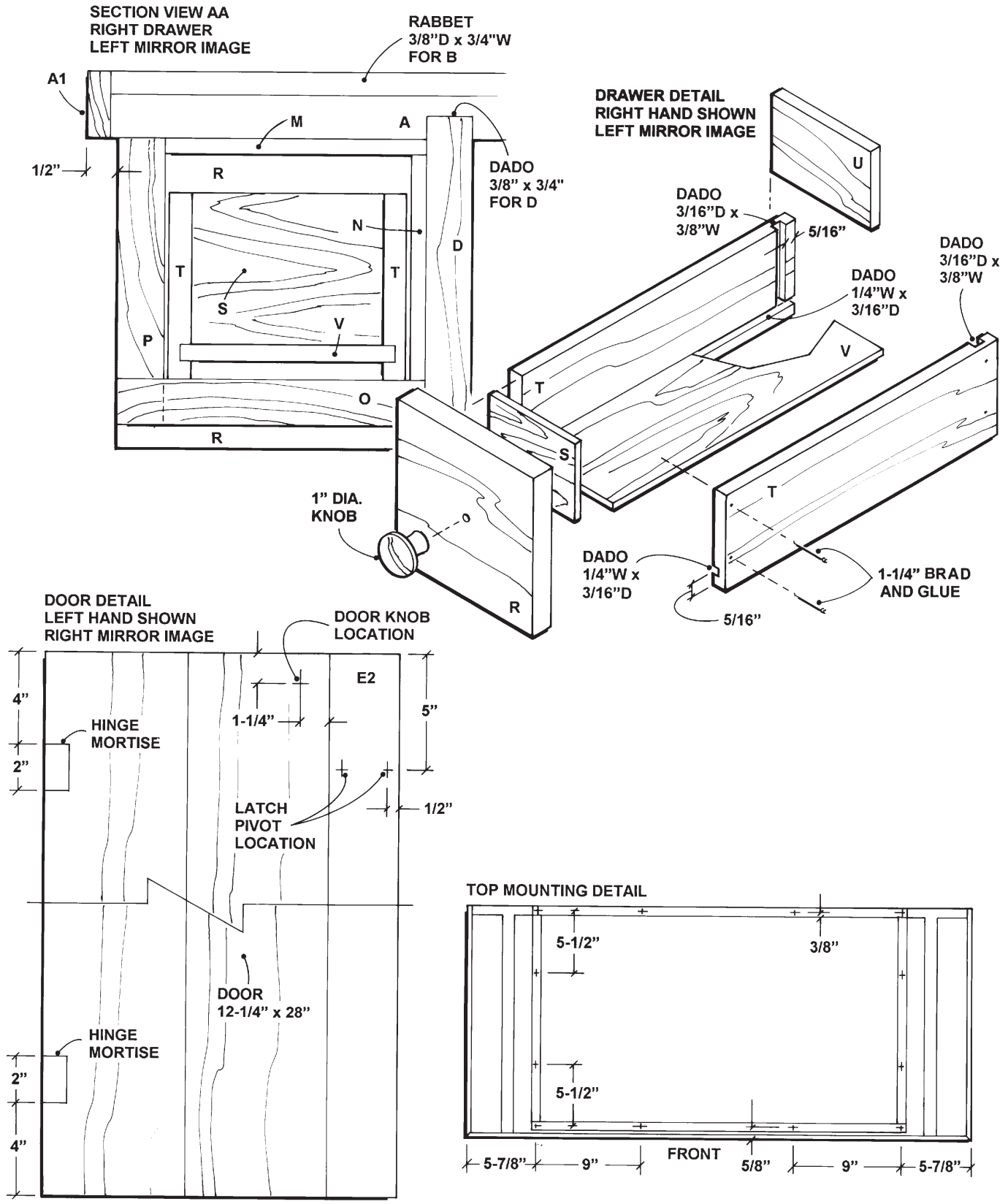

BUYING LIST

KEY	PART	BUY	MATERIAL
A	Top	1/8' 5/4 x 8 1/4' 5/4 x 6	Pine
B	Backsplash, rear	1/4' 1 x 6	Pine
C	Backsplash, ends	1/4', 5/4 x 6	
D	Sides, carcass	2/6' 1 x 8 1/6' 1 x 4	Pine
E1	Stiles	1/6' 1 x 4	Pine
E2	Stile, middle	1/3' 1 x 4	Pine
F1	Door stop	1/3' 1 x 2	Pine
F, G	Top Rail, front Top Rail, back	1/6' 1 x 4	Pine
H	Shelf	1/3' 1 x 8 1/3' 1 x 6	Pine
I	Back	1/4 x x	Plywood
J	Bottom shelf	1/6' 1 x 8 1/3' 1 x 4	Pine
K	Shelf cleats	From scrap box	Pine
L	Doors	1/6' 1 x 8 1/6' 1 x 6	Pine

Misc. Carpenter's glue, assorted grits sandpaper, 1-1/2 and 2-in. nails, 1-1/4 in. brads, two 7/8 or 1-in. dia. wooden knobs (drawers), two 1-1/4 in. wooden knobs (doors), two single magnetic catches, no. 800-498 from Woodworkers Supply, Casper, WY, 1-800-645-9292, two pair brass hinges 1-5/8 x 1-1/2 in., 1-1/4 in. no. 8 rh. screws (for turnbuttons).

Note: You should be able to cut the parts for the drawer cases and drawers from stock saved in your shop scrap box. If not, pick up 1/4' 1 x 6.

CUTTING LIST

NOTE: The actual dimensions shown on the chart below were the actual measurements taken from the prototype cabinet built in our shop. Do as craftsmen do and always check the dimensions given before doing any cutting. Do this because there can be variations on your project. If you find a variation — for example, the stiles on our original cabinet were 28-1/8" long. You may find that yours differ by 1/16" more or less. Remember, you are working with wood which can vary considerably.

If you do have a measurement variation, simply change the dimension in the table below.

KEY	PART	PCS.	DIMENSIONS
A	Top	1	1-1/16 x 19-1/16 x 42"
A1	Surround, ends	2	3/8 x 1-1/16 x 19-7/16"
A2	Surround, front	1	3/8 x 1-1/16 x 42-3/4"
B	Backsplash, rear	1	3/4 x 3-5/8 x 42-3/4"
C	Backsplash, ends	2	1-1/16 x 3-5/8 x 18-7/8"
D	Carcass sides	2	3/4 x 18 x 35-3/8"
E1	Stiles	2	3/4 x 2 x 28-1/8"
E2	Stile, middle	1	3/4 x 3 x 28-1/8"
F1	Door stop	1	3/4 x 1-1/2 x 29-3/4"
F	Rail, front	1	3/4 x 2-3/4 x 31-3/4"
G	Rail, back	1	3/4 x 3 x 31"
H	Shelf	1	3/4 x 13 x 29-7/8"
I	Back	1	1/4 x 28 x 30-7/8"
J	Bottom shelf	1	3/4 x 17-1/2 x 31"
K	Shelf cleats	4	3/4 x 1 x 17-5/8"
L	Doors	2	3/4 x 12-1/8 x 28-1/8" (see note a)

Note a). Measure the actual door openings in cabinet and build doors to suit.

DRAWER PARTS**Cases**

M	Top plate	2	1/4 x 4-1/4 x 11-3/8"
N	Side plates	2	1/4 x 3-5/8 x 11-3/8"
O	Case bottom	2	3/4 x 5 x 12-1/8"
P	Case side	2	3/4 x 4-5/8 x 12-1/8"
Q	Case back	2	3/4 x 3-7/8 x 4-1/4"

Drawers**

R	Drawer front	2	3/4 x 5 x 5"
S	False front	2	1/4 x 2-7/16 x 3-1/8"
T	Sides	4	3/8 x 3 x 10-1/16"
U	Back	2	3/8 x 2-7/16 x 3-5/8"
V	Bottom	2	1/4 x 3-1/2 x 10"

**Check drawer case dimensions to verify drawer (parts) sizes. Adjust measurements, if necessary, and cut your drawer parts to suit the openings in your cabinet.

NOTES

- The Buy column lists the lumber in lumberyard language. Your instructor has probably already covered the subject of buying lumber; that is, lumber is purchased using *nominal* dimensions, which are not the same as *actual* dimensions. Thus, for example, the listing (*nominally*) 1/5, 1 x 6 means you want one 5-ft. length of 1 x 6. The *actual* dimension for this board is 3/4 x 5-1/2 inches by 60 inches long.
- 5/4 in lumber jargon means five quarters. Bear in mind that this is the nominal dimension and that 5/4 stock, when dressed, can vary from 1-1/16 to 1-1/8 in. actual, depending upon the sawmill it is from.

Bring the above materials list to the lumberyard with you when you go to buy the materials.